

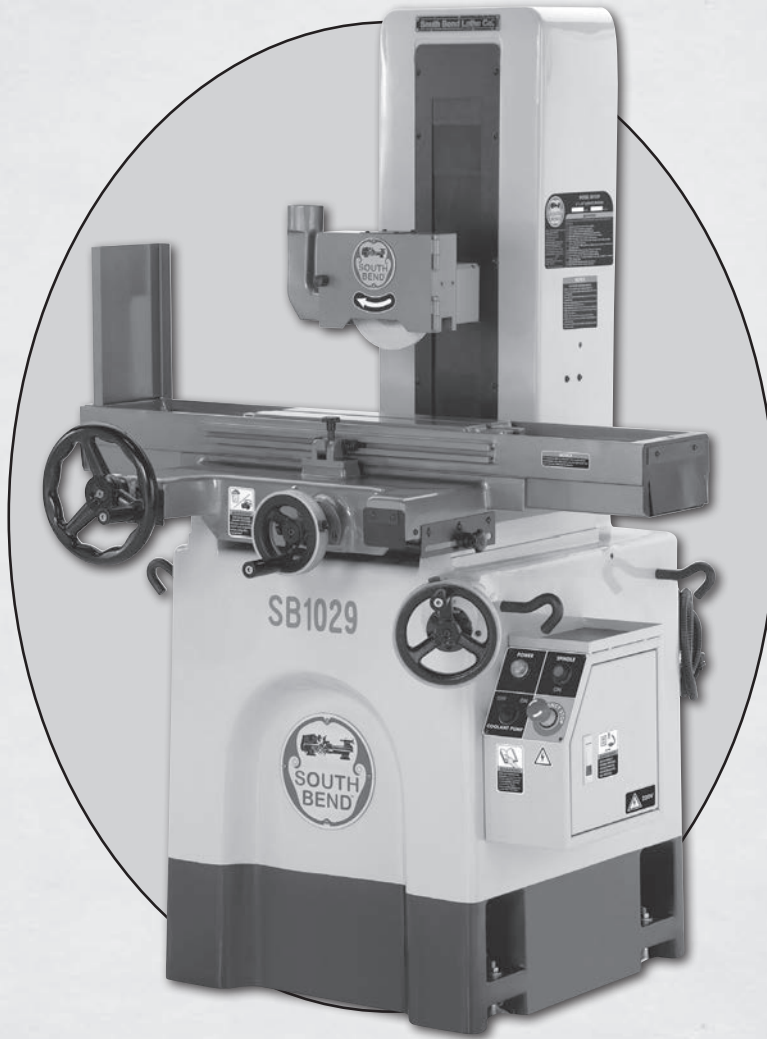

6" x 18" SURFACE GRINDER

MODEL SB1029



OWNER'S MANUAL

South Bend Lathe Co.[®]

Hundreds of Thousands of Lathes Sold With a Tradition of Quality Since 1906!



Scope of Manual

This manual helps the reader understand the machine, how to prepare it for operation, how to control it during operation, and how to keep it in good working condition. We assume the reader has a basic understanding of how to operate this type of machine, but that the reader is not familiar with the controls and adjustments of this specific model. As with all machinery of this nature, learning the nuances of operation is a process that happens through training and experience. If you are not an experienced operator of this type of machinery, read through this entire manual, then learn more from an experienced operator, schooling, or research before attempting operations. Following this advice will help you avoid serious personal injury and get the best results from your work.

Manual Feedback

We've made every effort to be accurate when documenting this machine. However, errors sometimes happen or the machine design changes after the documentation process—so the manual may not exactly match your machine. If a difference between the manual and machine leaves you in doubt, contact our customer service for clarification.

We highly value customer feedback on our manuals. If you have a moment, please share your experience using this manual. What did you like about it? Is there anything you would change to make it better? Did it meet your expectations for clarity, professionalism, and ease-of-use?

South Bend Lathe, Inc.
c/o Technical Documentation Manager
P.O. Box 2027
Bellingham, WA 98227
Email: manuals@southbendlathe.com

Updates

For your convenience, any updates to this manual will be available to download free of charge through our website at:

www.southbendlathe.com

Customer Service

We stand behind our machines. If you have any service questions, parts requests or general questions about the machine, feel free to contact us.

South Bend Lathe Co.
P.O. Box 2027
Bellingham, WA 98227
Phone: (360) 734-1540
Parts Department: (417) 886-2954
Fax: (360) 676-1075 (International)
Fax: (360) 734-1639 (USA Only)
Email: cs@southbendlathe.com

Table of Contents

INTRODUCTION.....	2	Wheel Inspection.....	23
About This Machine.....	2	Ring Test	23
Capabilities	2	Removing & Installing Grinding Wheels	24
Features	2	Removing & Installing Wheel & Hub	26
Identification	3	Wheel Dressing	28
Machine Specifications	4	Wheel Balancing	29
SAFETY.....	6	Magnetic Chuck	31
Understanding Risks of Machinery	6	Dust Port Positioning	31
Basic Machine Safety	6	Setup for a Typical Grinding Operation	31
Additional Surface Grinder Safety	8	Grinder Operation	31
PREPARATION	9	Using the Surface Grinder	32
Preparation Overview.....	9	Grinding Tips	32
Things You'll Need.....	9	MAINTENANCE	33
Power Supply Requirements	10	Maintenance Schedule.....	33
Availability.....	10	Basic Lubrication	33
Full-Load Current Rating	10	Changing Oil & Adjusting Oil Flow.....	34
Circuit Information.....	10	Removing Table Backlash	35
Circuit Requirements for 220V	10	TROUBLESHOOTING.....	36
Circuit Requirements for 440V	10	SERVICE.....	38
Grounding Requirements	11	Machine Storage	38
Extension Cords	11	ELECTRICAL.....	39
Unpacking	12	Electrical Safety Instructions	39
Inventory	12	Rewiring for 440V	40
Cleaning & Protecting	13	Hardwiring to Power Source	40
Location	14	220V Electrical Components	42
Lifting & Moving.....	15	220V Electrical Box	43
Leveling & Mounting.....	15	440V Electrical Components	44
Leveling	15	Electrical Box	45
Bolting to Concrete Floors.....	16	PARTS.....	46
Assembly	16	Column	46
Power Connection	18	Elevation Control.....	47
Initial Lubrication	18	Table	48
Inspections & Adjustments	18	Base	49
Test Run	19	Saddle	50
OPERATION.....	20	Main Assembly List.....	51
Operation Overview.....	20	Tools.....	52
Controls	21	Electrical	53
Wheel Selection.....	22	Machine Labels	54
Abrasive Type.....	22	Machine Labels List	55
Grit Size.....	22	WARRANTY & RETURNS.....	57
Grade	22		

About This Machine

Capabilities

This 6 x 18" Surface Grinder allows you to smooth the surface of metallic workpieces. It utilizes a table that moves on a horizontal plane and a grinding wheel that moves along a vertical axis. By mounting a workpiece to the table, then moving the table and the grinding wheel during the grinding process, extremely small amounts of material can be removed to create high-tolerance flat surfaces.

One example of this type of work is the table surface of a metalworking or woodworking machine that needs to be made perfectly flat. By removing the table from the machine and processing it with a surface grinder, a perfectly flat surface can be created.

Another example of this type of work is in the automotive industry. When a head gasket needs replacing, it is common practice to resurface the engine head to make sure it is perfectly flat, in case any warping has occurred.

Features

The SB1029 is equipped with three easy-to-reach front-mounted handwheels for controlling table movement and grinding wheel elevation.

An integrated lubrication system uses a central oil pump to lubricate the major moving parts on all three axes, ensuring smooth and precise grinding results.

The dust port can be connected to a chip extraction system to pull away waste material and fumes created during the grinding process, resulting in a cleaner and safer work environment.

The included diamond dresser is used to true the grinding wheel, ensuring high-precision results.

Aside from these features, we designed this machine to be extremely solid and durable. With thick, hardened steel ways, cast-iron construction, and Allen Bradley electrical components, this South Bend surface grinder is built to last.

Identification

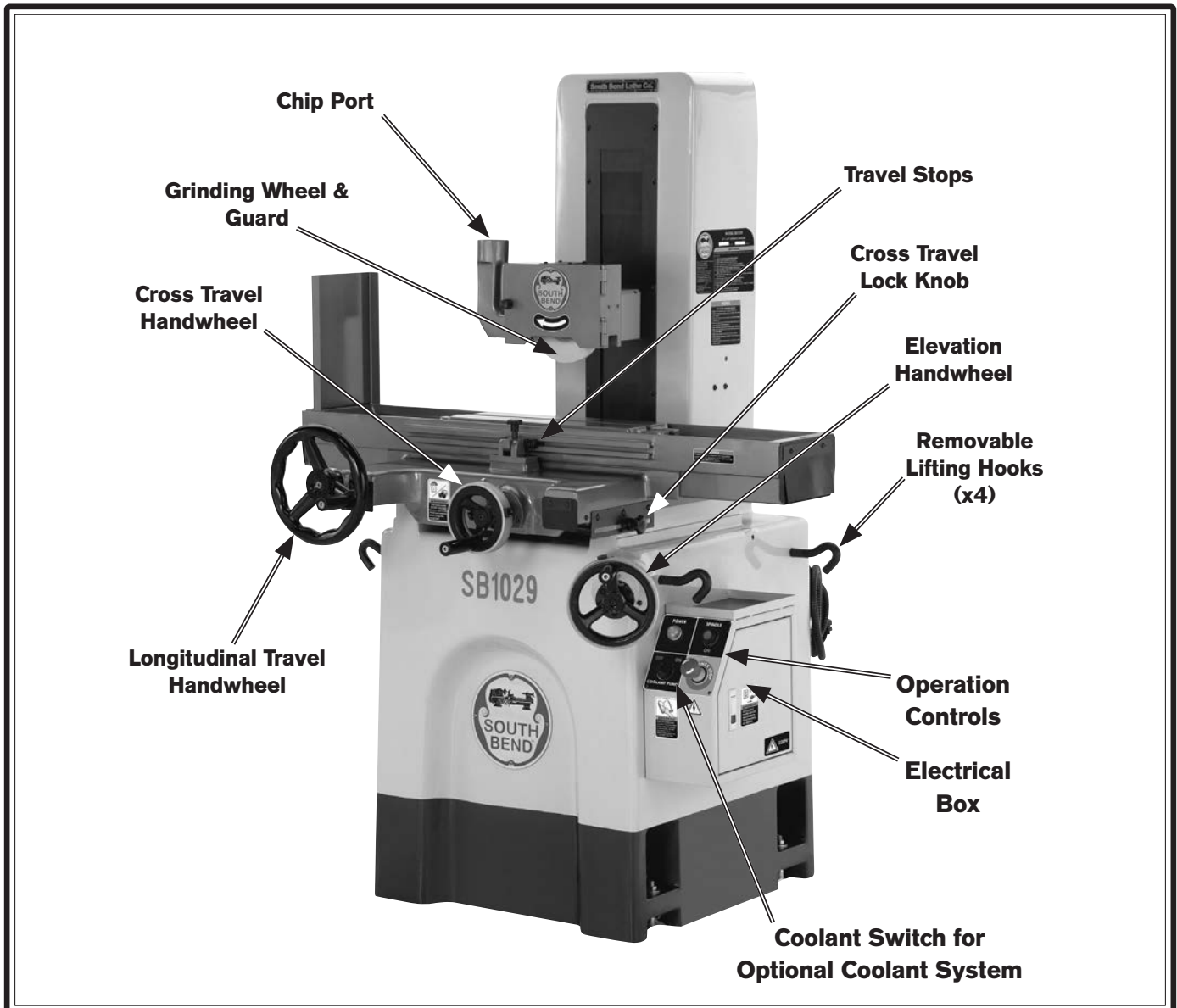

Figure 1. Identification.

!WARNING

Serious personal injury could occur if you connect the machine to power before completing the setup process. **DO NOT** connect power until instructed to do so later in this manual.

!WARNING

Untrained users have an increased risk of seriously injuring themselves with this machine. Do not operate this machine until you have understood this entire manual and received proper training.



Model SB1029 Surface Grinder 6" x 18"

Product Dimensions

Weight..... 1676 lbs.
 Width (side-to-side) x Depth (front-to-back) x Height..... 66-1/4 x 47-5/16 x 67-3/4 in.
 Footprint (Length x Width)..... 28 x 26-1/4 in.

Shipping Dimensions

Type..... Wood Crate
 Content..... Machine
 Weight..... 1904 lbs.
 Length x Width x Height..... 53 x 78 x 45 in.

Electrical

Power Requirement..... 220V or 440V, 3-Phase, 60 Hz
 Prewired Voltage..... 220V
 Full-Load Current Rating..... 4.2A at 220V, 2.4A at 440V
 Minimum Circuit Size..... 15A at 220V, 15A at 440V
 Connection Type..... Cord at 220V, Perman
 Power Cord Included..... Yes
 Power Cord Length..... 7 ft.
 Power Cord Gauge..... 14 AWG
 Plug Included..... No
 Recommended Plug Type..... 15-15 for 220V
 Switch Type..... Control Panel w/Magnetic Switch Protection
 Voltage Conversion Kit..... PSB1029510 for 440V
 Recommended Phase Converter..... G5844

Motors

Oil Pump

Horsepower..... 25W
 Type..... Electromagnetic Solenoid
 Bearings..... Sealed & Permanently Lubricated

Main

Horsepower..... 1.5 HP
 Phase..... 3-Phase
 Amps..... 4.2A/2.4A
 Speed..... 3450 RPM
 Type..... TEFC Induction
 Power Transfer Direct Drive
 Bearings..... Shielded & Permanently Lubricated

Main Specifications**Operation Info**

Max. Distance Wheel to Table.....	15-5/8 in.
Max. Distance Table to Spindle Center.....	19-3/16 in.
Longitudinal Travel.....	19-3/8 in.
Cross Travel.....	7-9/16 in.
Spindle Speed.....	3450 RPM
Grinding Wheel Bore.....	1-1/4 in.
Grinding Wheel Diameter.....	7 in.
Grinding Wheel Width.....	1/2 in.
Vertical Handwheel Graduation.....	0.0002 in.
Vertical Handwheel Revolution.....	0.05 in.
Crossfeed Handwheel Graduation.....	0.001 in.
Crossfeed Handwheel Revolution.....	0.2 in.

Table Info

Table Size Length.....	17-3/4 in.
Table Size Width.....	5-3/4 in.
Table Size Thickness.....	2-3/4 in.
Floor to Table Height.....	39-5/8 in.
T-Slot Size Width.....	0.067 in.
T-Slot Size Height.....	0.098 in.
Stud Size.....	1/2 in.

Construction

Table.....	Meehanite Cast Iron
Body.....	Meehanite Cast Iron
Base.....	Meehanite Cast Iron
Spindle Bearing Type.....	Angular Contact, P5 Class (ABEC-5)
Paint Type/Finish.....	Urethane

Other

Country of Origin	Taiwan
Warranty	1 Year
Approximate Assembly & Setup Time	2 Hours
Serial Number Location	ID Label, Right-Side of Column
ISO 9001 Factory	No
Certified by a Nationally Recognized Testing Laboratory (NRTL)	No

Features

Constant Oil-Flow Lubrication System for Lead Screws and Ways
 Grinding Wheel Included
 Allen-Bradley Electrical Components
 Japanese NSK Bearings
 Precision Hand-Scraped Ways
 Precision Ball Bearing Slideways
 Stand Built from One-Piece Heavy-Duty Cast-Iron Casting
 Diamond Wheel Dressing Tool w/Base
 Balancing Arbor and Hub
 Hub Puller
 Toolbox w/Tools Included



Understanding Risks of Machinery

Operating all machinery and machining equipment can be dangerous or relatively safe depending on how it is installed and maintained, and the operator's experience, common sense, risk awareness, working conditions, and use of personal protective equipment (safety glasses, respirators, etc.).

The owner of this machinery or equipment is ultimately responsible for its safe use. This responsibility includes proper installation in a safe environment, personnel training and usage authorization, regular inspection and maintenance, manual availability and comprehension, application of safety devices, integrity of cutting tools or accessories, and the usage of approved personal protective equipment by all operators and bystanders.

The manufacturer of this machinery or equipment will not be held liable for injury or property damage from negligence, improper training, machine modifications, or misuse. Failure to read, understand, and follow the manual and safety labels may result in serious personal injury, including amputation, broken bones, electrocution, or death.

The signals used in this manual to identify hazard levels are as follows:

 DANGER	<i>Death or catastrophic harm WILL occur.</i>	 CAUTION	<i>Moderate injury or fire MAY occur.</i>
 WARNING	<i>Death or catastrophic harm COULD occur.</i>	NOTICE	<i>Machine or property damage may occur.</i>

Basic Machine Safety

Owner's Manual: All machinery and machining equipment presents serious injury hazards to untrained users. To reduce the risk of injury, anyone who uses THIS item MUST read and understand this entire manual before starting.

Personal Protective Equipment: Operating or servicing this item may expose the user to flying debris, dust, smoke, dangerous chemicals, or loud noises. These hazards can result in eye injury, blindness, long-term respiratory damage, poisoning, cancer, reproductive harm or hearing loss. Reduce your risks from these hazards by wearing approved eye protection, respirator, gloves, or hearing protection.

Trained/Supervised Operators Only: Untrained users can seriously injure themselves or bystanders. Only allow trained and properly supervised personnel to operate this item. Make sure safe operation instructions are clearly understood. If electrically powered, use padlocks and master switches, and remove start switch keys to prevent unauthorized use or accidental starting.

Guards/Covers: Accidental contact with moving parts during operation may cause severe entanglement, impact, cutting, or crushing injuries. Reduce this risk by keeping any included guards/covers/doors installed, fully functional, and positioned for maximum protection.

Entanglement: Loose clothing, gloves, neckties, jewelry or long hair may get caught in moving parts, causing entanglement, amputation, crushing, or strangulation. Reduce this risk by removing/securing these items so they cannot contact moving parts.

Mental Alertness: Operating this item with reduced mental alertness increases the risk of accidental injury. Do not let a temporary influence or distraction lead to a permanent disability! Never operate when under the influence of drugs/alcohol, when tired, or otherwise distracted.

Safe Environment: Operating electrically powered equipment in a wet environment may result in electrocution; operating near highly flammable materials may result in a fire or explosion. Only operate this item in a dry location that is free from flammable materials.

Electrical Connection: With electrically powered equipment, improper connections to the power source may result in electrocution or fire. Always adhere to all electrical requirements and applicable codes when connecting to the power source. Have all work inspected by a qualified electrician to minimize risk.

Disconnect Power: Adjusting or servicing electrically powered equipment while it is connected to the power source greatly increases the risk of injury from accidental startup. Always disconnect power **BEFORE** any service or adjustments, including changing blades or other tooling.

Secure Workpiece/Tooling: Loose workpieces, cutting tools, or rotating spindles can become dangerous projectiles if not secured or if they hit another object during operation. Reduce the risk of this hazard by verifying that all fastening devices are properly secured and items attached to spindles have enough clearance to safely rotate.

Chuck Keys or Adjusting Tools: Tools used to adjust spindles, chucks, or any moving/rotating parts will become dangerous projectiles if left in place when the machine is started. Reduce this risk by developing the habit of always removing these tools immediately after using them.

Work Area: Clutter and dark shadows increase the risks of accidental injury. Only operate this item in a clean, non-glaring, and well-lighted work area.

Properly Functioning Equipment: Poorly maintained, damaged, or malfunctioning equipment has higher risks of causing serious personal injury compared to those that are properly maintained. To reduce this risk, always maintain this item to the highest standards and promptly repair/service a damaged or malfunctioning component. Always follow the maintenance instructions included in this documentation.

Unattended Operation: Electrically powered equipment that is left unattended while running cannot be controlled and is dangerous to bystanders. Always turn the power **OFF** before walking away.

Health Hazards: Certain cutting fluids and lubricants, or dust/smoke created when cutting, may contain chemicals known to the State of California to cause cancer, respiratory problems, birth defects, or other reproductive harm. Minimize exposure to these chemicals by wearing approved personal protective equipment and operating in a well ventilated area.

Difficult Operations: Attempting difficult operations with which you are unfamiliar increases the risk of injury. If you experience difficulties performing the intended operation, **STOP!** Seek an alternative method to accomplish the same task, ask a qualified expert how the operation should be performed, or contact our Technical Support for assistance.

Additional Surface Grinder Safety

- 1. Eye Protection:** Grinding causes small particles to become airborne at a high rate of speed creating a risk of eye injury. ALWAYS wear eye protection when using this machine.
- 2. Wheel Speed Rating:** Wheels operated at a faster speed than they are rated for may break or fly apart and impact the operator or bystanders. Before mounting a new wheel, be sure the wheel RPM rating is equal to or higher than the speed of the grinder.
- 3. Hand/Wheel Contact:** Grinding wheels have the capability of removing a lot of skin fast. Make sure the workpiece is securely clamped to the table, then position your hands a safe distance away when grinding. Avoid wearing gloves as they may get caught in the grinding wheel and cause serious entanglement injuries.
- 4. Ring Test:** Perform a "ring test" on grinding wheels before installation to ensure that they are safe to use. A wheel that does not pass the ring test may break or fly apart during operation.
- 5. Starting Grinder:** If a wheel IS damaged, it will usually fly apart shortly after start-up. Standing in the wheel path increases the risk of impact injuries. To protect yourself, always stand out of the wheel path when turning the grinder ON.
- 6. Cracked Wheel:** Cracked wheels may break and fly apart during operation, increasing the risk of impact injuries. Replace cracked wheels immediately!
- 7. Lung Protection:** Grinding produces hazardous dust, which may cause long-term respiratory problems if breathed. Always wear a NIOSH approved dust mask or respirator when grinding.
- 8. Workpiece Contact:** A heavy impact on a grinding wheel or attempting too deep of a cut can cause it to break or fly apart, causing serious personal injuries. Avoid jamming the workpiece into the wheel to reduce this risk.
- 9. Wheel Flanges:** Only use the flanges included with the grinder when mounting wheels. Other flanges may not properly secure the wheel and could cause the wheel to fly off or break apart.
- 10. Fire Hazard:** DO NOT connect a surface grinder to a dust collection system that is used with woodworking machines. Sparks emitted from the grinding process may ignite wood particles, resulting in fire or explosion. Only use a metal-specific dust collection system with this machine.

Preparation Overview

The list below outlines the basic process to follow to prepare your machine for operation. Specific steps for each of these points will be covered in detail later in this section.

The typical preparation process is as follows:

1. Unpack the machine and inventory the contents of the box/crate.
2. Clean the machine and its components.
3. Identify an acceptable location for the machine and move it to that location.
4. Level the machine and either bolt it to the floor or place it on mounts.
5. Finish assembling the machine by installing the necessary components from the inventory, and make any necessary adjustments or inspections to ensure the machine is ready for operation.
6. Connect the machine to the power source.
7. Test run the machine to make sure it functions properly and is ready for operation.

Things You'll Need

During the setup process, operation, and maintenance of your machine, you'll need the following items:

For Lifting

- A forklift or other power lifting device rated for the weight of the machine.
- Lifting Strap or Chain (rated for at least 2500 lbs.)

For Power Connection

- A power source that meets the minimum circuit requirements for this machine. (Refer to the **Power Supply Requirements** section for details.)
- A qualified electrician to ensure a safe and code-compliant connection to the power source.

For Assembly

- Another Person
- Cotton Rags
- Mineral Spirits
- Safety Glasses
- Wrench 19mm
- Oil Can Filled with Oil Listed in Maintenance

Power Supply Requirements

Availability

Before installing the machine, consider the availability and proximity of the required power supply circuit. If an existing circuit does not meet the requirements for this machine, a new circuit must be installed.

To minimize the risk of electrocution, fire, or equipment damage, installation work and electrical wiring must be done by an electrician or qualified service personnel in accordance with applicable electrical codes and safety standards.



! WARNING
Electrocution or fire may occur if machine is not correctly grounded and attached to the power supply. Use a qualified electrician to ensure a safe power connection.

Full-Load Current Rating

The full-load current rating is the amperage a machine draws at 100% of the rated output power. On machines with multiple motors, this is the amperage drawn by the largest motor or sum of all motors and electrical devices that might operate at one time during normal operations.

Full-Load Rating at 110V 4.2 Amps
Full-Load Rating at 220V 2.4 Amps

The full-load current is not the maximum amount of amps that the machine will draw. If the machine is overloaded, it will draw additional amps beyond the full-load rating.

If the machine is overloaded for a sufficient length of time, damage, overheating, or fire may result—especially if connected to an undersized circuit. To reduce the risk of these hazards, avoid overloading the machine during operation and make sure it is connected to a power supply circuit that meets the requirements in the following section.

Circuit Information

A power supply circuit includes all electrical equipment between the main breaker box or fuse panel in your building and the incoming power connections inside the machine. This circuit must be safely sized to handle the full-load current that may be drawn from the machine for an extended period of time. (If this machine is

! CAUTION

For your own safety and protection of property, consult an electrician if you are unsure about wiring practices or applicable electrical codes.

Note: The circuit requirements in this manual are for a dedicated circuit—where only one machine will be running at a time. If this machine will be connected to a shared circuit where multiple machines will be running at the same time, consult a qualified electrician to ensure the circuit is properly sized.

Circuit Requirements for 220V

This machine is prewired to operate on a 220V power supply circuit that has a verified ground and meets the following requirements:

Nominal Voltage 220V/240V
Cycle 60 Hz
Phase 3-Phase
Circuit Rating 15 Amps
Plug/Receptacle NEMA L15-15

Circuit Requirements for 440V

This machine can be converted to operate on a 440V power supply. To do this, follow the **Voltage Conversion** instructions included in this manual. The intended 440V circuit must have a verified ground and meet the following requirements:

Nominal Voltage 440V/480V
Cycle 60 Hz
Phase 3-Phase
Circuit Rating 15 Amps
**Plug/Receptacle
 Hardwire with Locking Switch**

Grounding Requirements

This machine must be grounded! In the event of certain types of malfunctions or breakdowns, grounding provides a path of least resistance for electric current in order to reduce the risk of

For 220V Connection (Prewired)

This machine is equipped with a power cord that has an equipment-grounding wire and a grounding plug (similar to the figure below). The plug must only be inserted into a matching receptacle (outlet) that is properly installed and grounded in accordance with all local codes and ordinances.

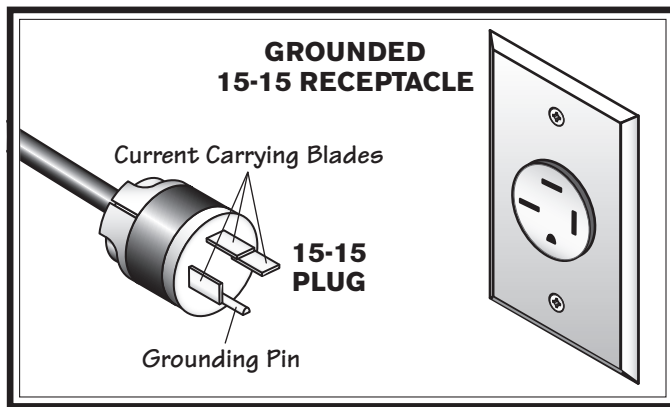

Figure 2. NEMA 15-15 plug and receptacle.

For 440V Connection

Power supply connections that are hardwired to the power source must be connected to a grounded metal permanent wiring system, or to a system having an equipment-grounding conductor.

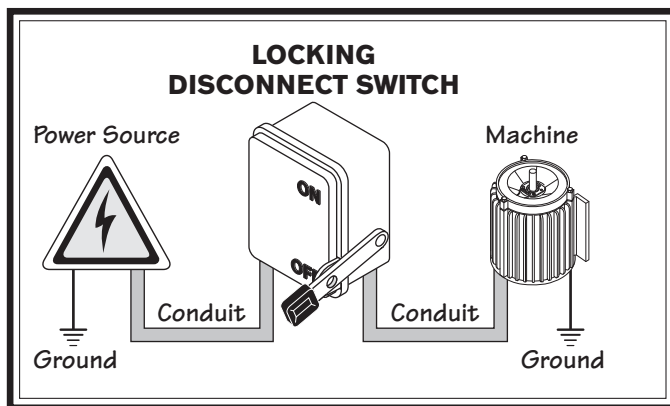

Figure 3. Locking disconnect switch.

!WARNING

Serious injury could occur if you connect the machine to power before completing the setup process. DO NOT connect to power until instructed later in this manual.

Improper connection of the equipment-grounding wire can result in a risk of electric shock. The wire with green insulation (with or without yellow stripes) is the equipment-grounding wire. If repair or replacement of the power cord or plug is necessary, do not connect the equipment-grounding wire to a live (current carrying) terminal.

Check with an electrician or qualified service personnel if you do not understand these grounding requirements, or if you are in doubt about whether the tool is properly grounded.

If you ever notice that a cord or plug is damaged or worn, disconnect it from power, and immediately replace it with a new one.

Extension Cords

We do not recommend using an extension cord with this machine. If you must use one, only use it if absolutely necessary and only on a temporary basis.

Extension cords cause voltage drop, which may damage electrical components and shorten motor life. Voltage drop increases as the extension cord size gets longer and the gauge size gets smaller (higher gauge numbers indicate smaller sizes).

Any extension cord used with this machine must contain a ground wire, match the required plug and receptacle listed in the **Circuit Requirements** for the applicable voltage, and meet the following requirements:

- Minimum Gauge Size.....16 AWG**
- Maximum Length (Shorter is Better)50 ft.**

Unpacking

This item was carefully packaged to prevent damage during transport. If you discover any damage, please immediately call Customer Service at (360) 734-1540 for advice. You may need to file a freight claim, so save the containers and all packing materials for possible inspection by the carrier or its agent.

Inventory

Main Inventory 1: (See Figure 4) Qty
A. Surface Grinder (Wheel Installed)..... 1

Tool Box Inventory: (See Figure 5) Qty
B. Column Elevation Handwheel 1
C. Column Elevation Handwheel Crank..... 1
D. Cast Iron Feet 5
E. Tool Box 1
F. Dressing Tool Base 1
G. Diamond-Tip Dressing Tool..... 1
H. Hub Puller 1
I. T-Bolt Set 1
J. Feet Studs 5
K. Standard Screw Driver #2..... 1
L. 10-Pc Hex Wrench Set
 (1.5, 2, 2.5, 3, 4, 5, 5.5, 6, 8, 10mm)..... 1
M. Spindle Wrench 47mm 1
N. Spindle Wrench 27mm 1
O. Adjustable Wrench 8" 1
P. Balancing Spindle 1

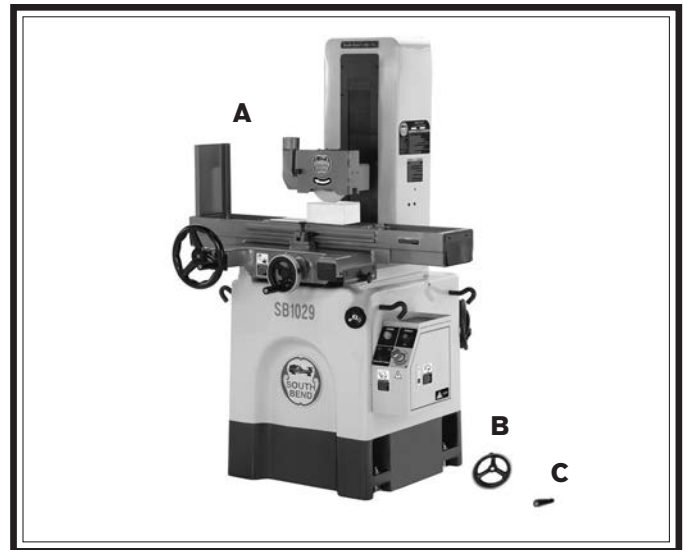

Figure 4. Main inventory.

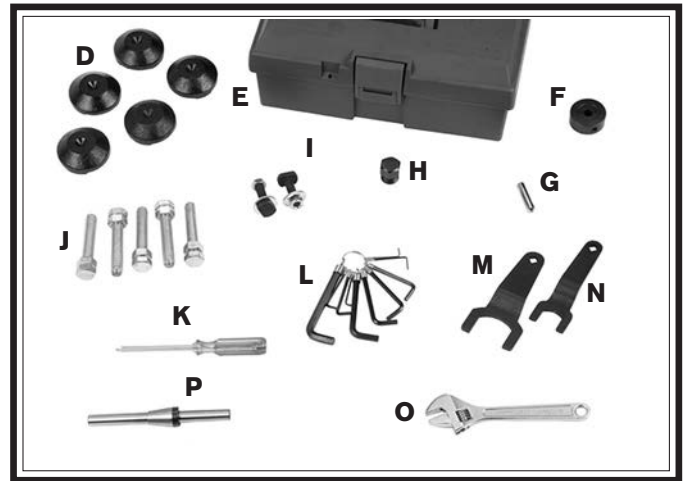

Figure 5. Small parts inventory.

Cleaning & Protecting

The unpainted surfaces are coated at the factory with a heavy-duty rust preventative that prevents corrosion during shipment and storage. The benefit of this rust preventative is that it works very well. The downside is that it can be time-consuming to thoroughly remove.

Be patient and do a careful job when cleaning and removing the rust preventative. The time you spend doing this will reward you with smooth-sliding parts and a better appreciation for the proper care of the unpainted surfaces.

Although there are many ways to successfully remove the rust preventative, the following process works well in most situations.

Before cleaning, gather the following:

- Disposable rags
- Cleaner/degreaser (certain citrus-based degreasers work extremely well and they have non-toxic fumes)
- Safety glasses & disposable gloves

Note: Automotive degreasers, mineral spirits, or WD•40 can be used to remove rust preventative. Before using these products, though, test them on an inconspicuous area of a painted surface to make sure they will not damage it.

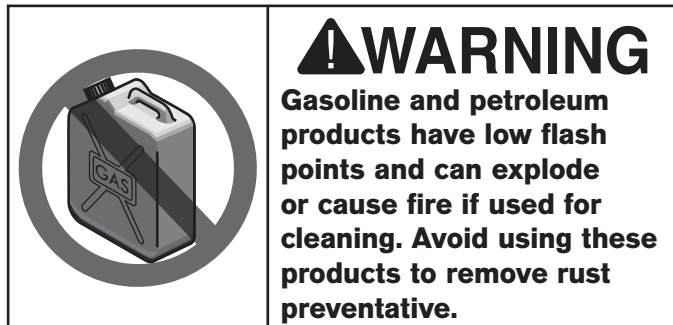

NOTICE

Avoid chlorine-based solvents, such as acetone or brake parts cleaner that may damage painted surfaces. Always follow the manufacturer's instructions when using any type of cleaning product.

Basic steps for removing rust preventative:

1. Put on safety glasses and disposable gloves.
2. Coat all surfaces that have rust preventative with a liberal amount of your cleaner or degreaser and let them soak for a few minutes.
3. Wipe off the surfaces. If your cleaner or degreaser is effective, the rust preventative will wipe off easily.

Note: To clean off thick coats of rust preventative on flat surfaces, such as beds or tables, use a PLASTIC paint scraper to scrape off the majority of the coating before wiping it off with your rag. (Do not use a metal scraper or it may scratch the surface.)

4. Repeat **Steps 2–3** as necessary until clean, then coat all unpainted surfaces with a quality metal protectant or light oil to prevent rust.

Location

Physical Environment

The physical environment where your machine is operated is important for safe operation and longevity of parts. For best results, operate this machine in a dry environment that is free from excessive moisture, hazardous or flammable chemicals, airborne abrasives, or extreme conditions. Extreme conditions for this type of machinery are generally those where the ambient temperature is outside the range of 41°–104°F; the relative humidity is outside the range of 20–95% (non-condensing); or the environment is subject to vibration, shocks, or bumps.

Electrical Installation

Place this machine near an existing power source. Make sure all power cords are protected from traffic, material handling, moisture, chemicals, or other hazards. Make sure to leave access to a means of disconnecting the power source or engaging a lockout/tagout device.

Lighting

Lighting around the machine must be adequate enough to perform operations safely. Shadows, glare, or strobe effects that may distract or impede the operator must be eliminated.

Weight Load

Refer to the **Machine Specifications** for the weight of your machine. Make sure that the surface upon which the machine is placed will bear the weight of the machine, additional equipment that may be installed on the machine, and the heaviest workpiece that will be used. Additionally, consider the weight of the operator and any dynamic loading that may occur when operating the machine.

Space Allocation

Consider the largest size of workpiece that will be processed through this machine and provide enough space around the machine for adequate operator material handling or the installation of auxiliary equipment. With permanent installations, leave enough space around the machine to open or remove doors/covers as required by the maintenance and service described in this manual.

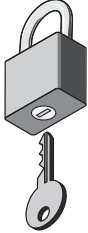
	<p>⚠ CAUTION Children or untrained people may be seriously injured by this machine. Only install in an access restricted location.</p>
---	---

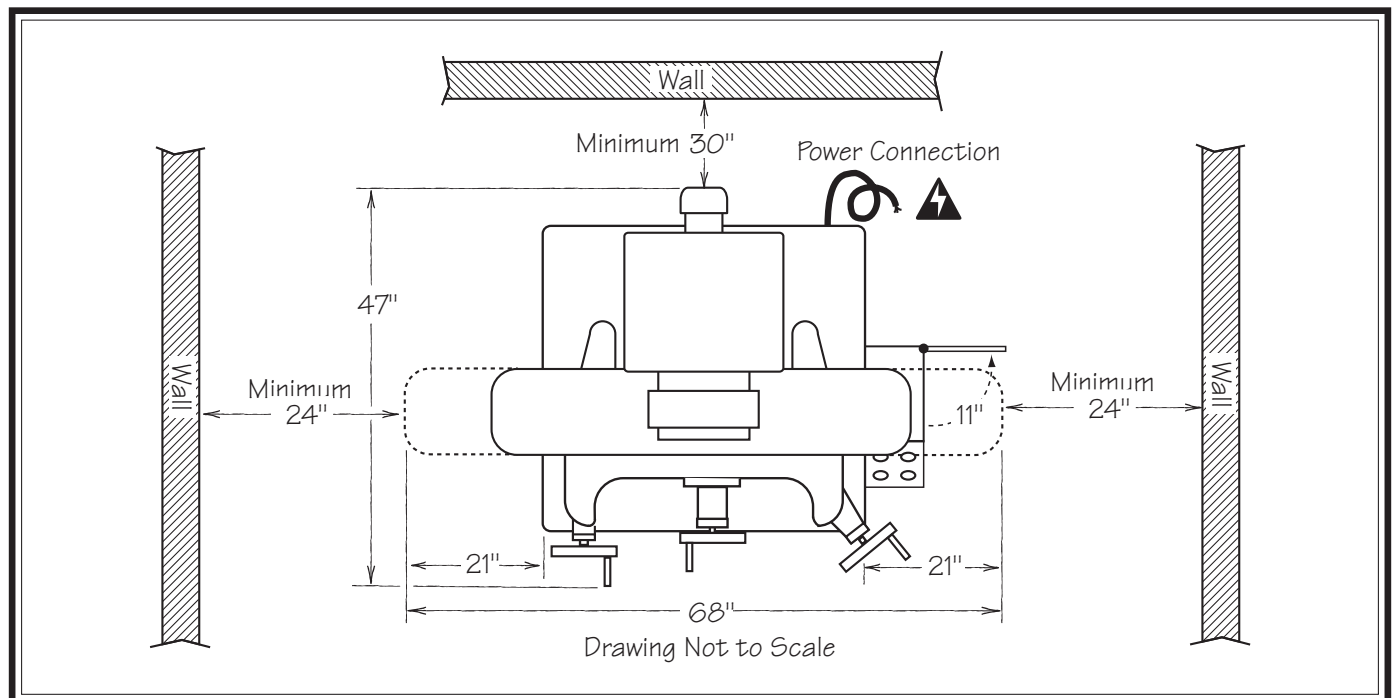
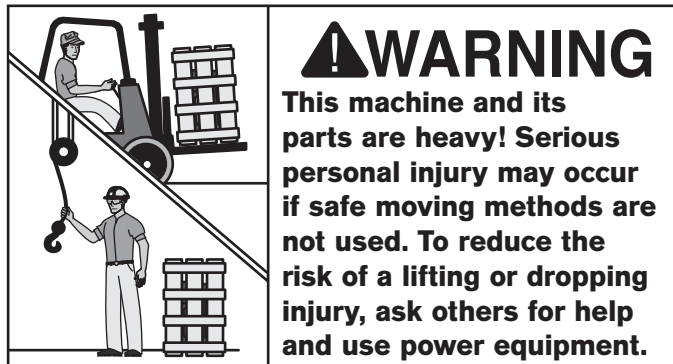

Figure 6. Space required for full range of movement.

Lifting & Moving



Unbolt the machine from the pallet and make sure that the table is locked in place. Connect lifting straps to all four lifting hooks (**Figure 7**) on the machine, use a hoist or forklift to lift the machine off the pallet, and move it to the suitable location. All hoisting equipment and straps must be rated to lift at least 2500 lbs.

NOTICE

Never attempt to move this machine without first installing the neoprene shipping seats (see Figure 14). These seats protect the longitudinal way and ball bearings from vibration, or possible moisture pitting if machine is to be put in long-term storage. Ignoring this notice, can lead to way or bearing damage which will void warranty.

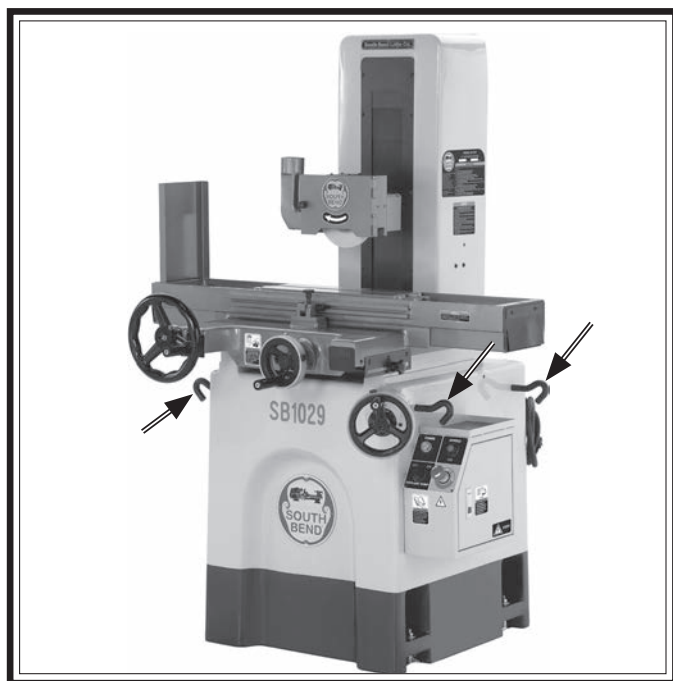

Figure 7. Lifting hooks (3 of 4 shown).

Leveling & Mounting

Generally, you can either bolt your machine to the floor or mount it on machine mounts. Although not required, we recommend that you secure the machine to the floor and level it while doing so. Because this is an optional step and floor materials may vary, hardware for securing the machine to the floor is not included.

NOTICE

We strongly recommend securing your machine to the floor if it is hardwired to the power source. Consult with your electrician to ensure compliance with local codes.

Leveling

Leveling machinery helps precision components, such as bed ways, remain straight and flat during the lifespan of the machine. Components on an unlevelled machine may slowly twist due to the dynamic loads placed on the machine during operation.

For best results, use a precision level that is at least 12" long and sensitive enough to show a distinct movement when a 0.003" shim (approximately the thickness of one sheet of standard newspaper) is placed under one end of the level.

See the figure below for an example of a high precision level.

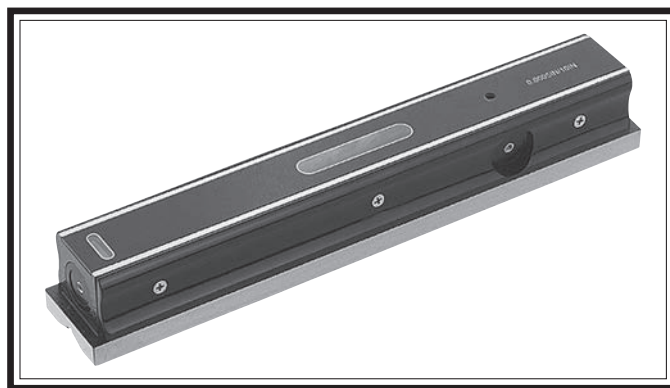

Figure 8. Example of a precision level.

Bolting to Concrete Floors

Lag screws and anchors, or anchor studs (below), are two popular methods for securing machinery to a concrete floor. We suggest you research the many options and methods for securing your machine and choose the best one for your specific application.

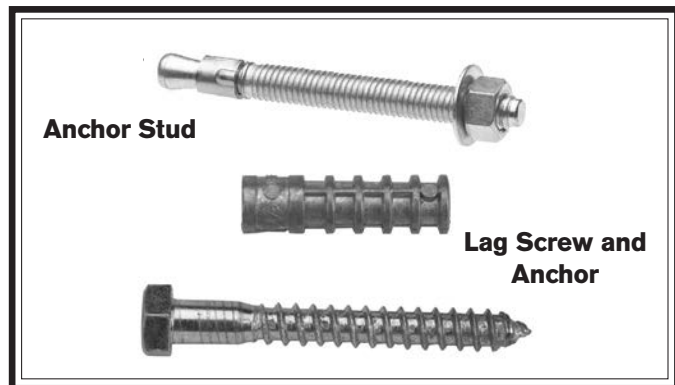

Figure 9. Common types of fasteners for bolting machinery to concrete floors.

Included with your machine are five cast-iron feet and adjustment studs. These feet are easily installed and provide a quick and easy method for machine leveling.

Assembly

If you desire to use the mounting feet included with your machine, proceed as follows.

To assemble the machine:

1. Thread one jam nut on each foot stud, and apply lithium grease or similar to the threads on the studs to ensure that the studs will not rust inside of the base should water from floor cleaning activities pose a problem.
2. From the top down, thread each stud into the machine base until the ends emerge from the underside of the base.
3. Slide a foot under each stud, and thread each stud into its foot until it is fully seated.
4. Tighten each stud until the machine is positioned approximately $\frac{1}{2}$ " off of the floor, as shown in **Figure 10**.

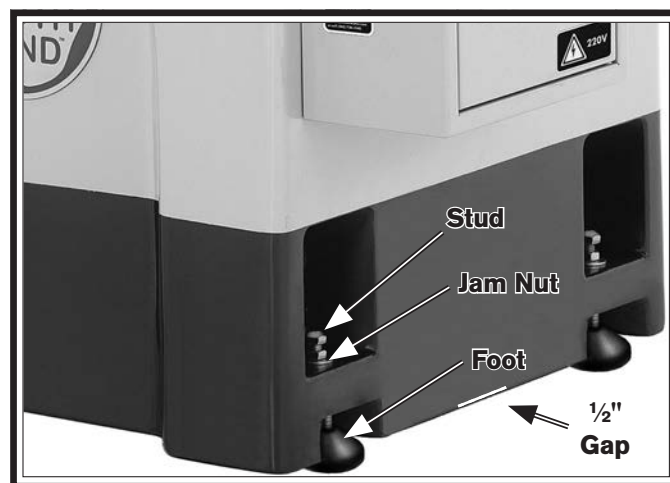

Figure 10. Machine feet.

5. Cut or remove the handwheel shipping straps that tie the handwheels together.

6. Locate the flat shown in **Figure 11** on the headstock elevation handwheel shaft. Next align the set screw on the elevation handwheel hub with the flat on the shaft, and slide the handwheel (see **Figure 12**) onto the shaft until it stops.

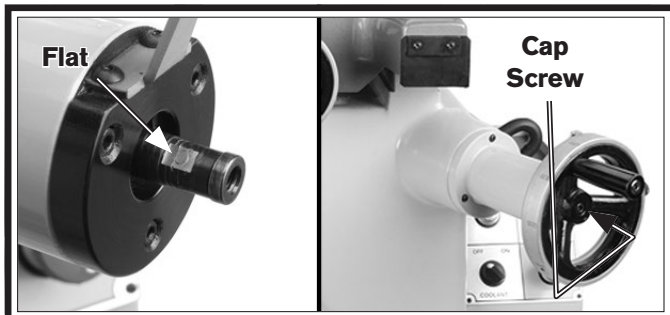

Figure 11. Headstock elevation handwheel.

7. Tighten the set screw against the shaft flat, secure the handwheel to the shaft with the cap screw (see **Figure 11**), and install the handle onto the handwheel.
8. Rotate the headstock elevation handwheel counterclockwise to raise the headstock slightly, and remove the wooden support block (see **Figure 12**).

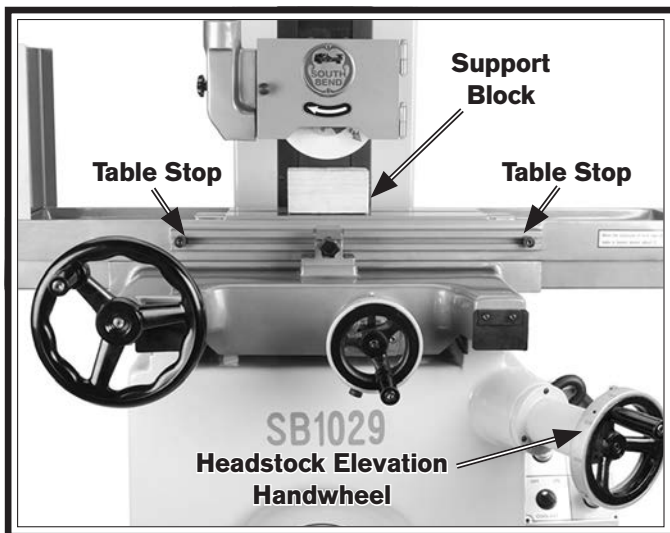

Figure 12. Table and headstock shipping position.

9. Reposition the table stops (see **Figure 12**) to the ends of the table.
10. At both ends of the table, lift up the rubber dust skirt, and locate the neoprene seat wires (two at each end, see **Figure 11**).

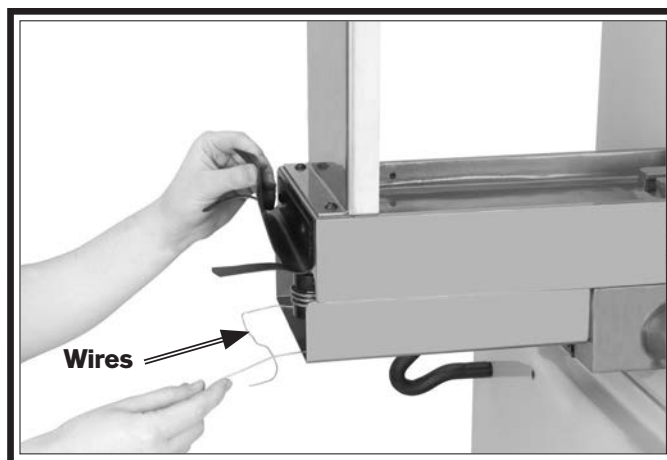

Figure 13. Neoprene shipping seat wires.

11. Have an assistant carefully lift up on the table so it is raised approximately an inch or two, use the wires to pull each neoprene seat out of its respective way (see **Figure 14**), then carefully lower the table onto the ball bearings. Keep the neoprene seats for future transport or storage.

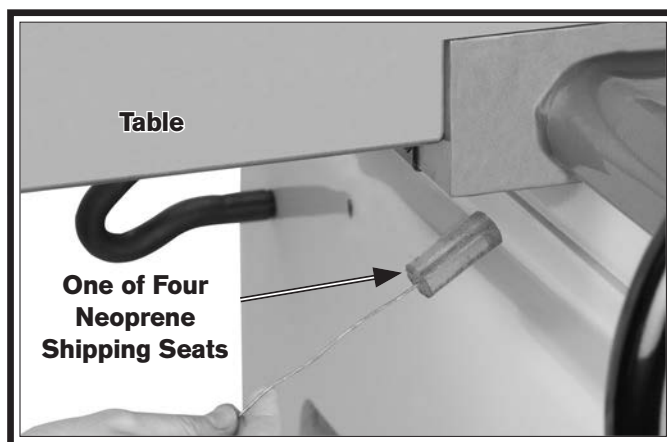
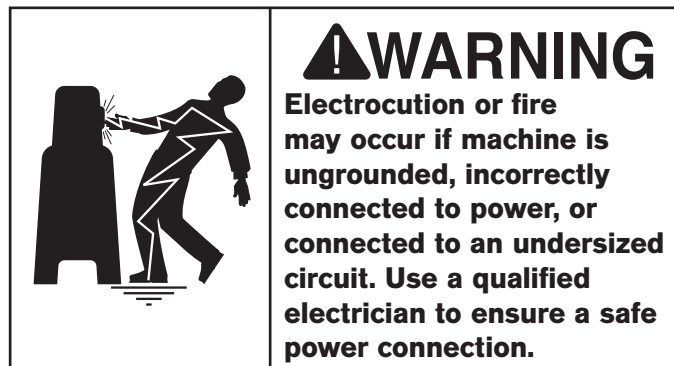

Figure 14. Neoprene shipping seat.

12. Repeat this step on the other end of the table and lubricate the machine as outlined in **Basic Lubrication**, on **Page 33**.
13. Place a precision level (see **Figure 8**) on the table surface and adjust the feet studs until the machine is perfectly level in the X- and Y-axis, then tighten the jam nuts. Recheck after 24 hours, and again in two weeks.
14. Remove the grinding wheel as outlined in **Removing & Installing Grinding Wheels** on **Page 23**. Next, perform the **Ring Test** on **Page 22**, and reinstall the wheel.

Power Connection



Once your machine is set up and assembled as previously described in this manual, it is ready to be connected to the power source.

- If you plan to use the machine at 220V, you will have to install the recommended plug and plug it into a receptacle on a 220V circuit that meets the requirements listed on **Page 10**.
- If you plan to use the machine at 440V, you will have to convert the machine for 440V and hardwire it to a 440V circuit that meets the requirements listed on **Page 10**. Refer to **Electrical**, beginning on **Page 39**.

Initial Lubrication

Your machine was lubricated at the factory, but we strongly recommend that you inspect all lubrication points yourself and provide additional lubrication if necessary. Refer to **Basic Lubrication** on **Page 33** for specific details and to fill the oil reservoir.



Inspections & Adjustments

The following list of adjustments were performed at the factory before your machine was shipped:

- **Table Backlash Adjustment** on **Page 35**
- **Ring Test** on **Page 23**
- **Wheel Dressing** on **Page 28**
- **Wheel Balancing** on **Page 29**
- **Changing Oil & Adjusting Oil Flow** on **Page 34**

Test Run

If this machine is new and being put into service, or if it has been in storage for a period of time, the machine and its safety features must be tested to ensure correct operation. Complete all preparation steps and lubrication as outlined in **Basic Lubrication** on **Page 33**. If you discover a problem with the operation of the machine or its safety components, do not operate it further until you have resolved the problem.

Refer to **Troubleshooting** on **Page 36** for solutions to common problems that may occur with surface grinders. If you need additional help, contact our Technical Support at (360) 734-1540.

To test run your machine:

1. Read and follow the safety instructions at the beginning of the manual, take the required safety precautions, and make sure the machine is set up and adjusted properly.
3. Clear away all tools and objects used during assembly and preparation.
4. Flush and fill the oil reservoir as instructed in **Basic Lubrication** on **Page 32** and verify that the oil pump is operating.
5. Connect the machine to the power source.
6. Push the OFF button in, then twist it clockwise so it pops out. When the OFF button pops out, the switch is reset and ready for operation (**Figure 15**).

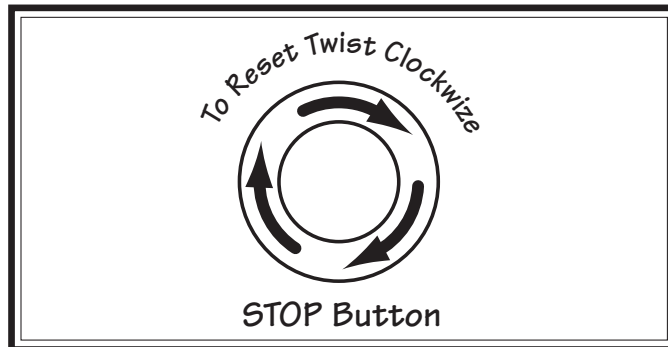

Figure 15. Machine stop button.

7. Verify that the machine is operating correctly by pushing the ON button.
 - When operating correctly, the machine runs smoothly with little or no vibration or rubbing noises.
 - Investigate and correct strange or unusual noises or vibrations before operating the machine further. Always stop the machine and disconnect it from power before investigating or correcting potential problems.
8. Press the OFF button to stop the machine.
9. WITHOUT resetting the switch, press the ON button. The machine should not start.
 - If the machine does not start, the OFF button safety feature is working correctly.
 - If the machine does start (with the stop button pushed in), immediately disconnect power to the machine. The OFF button safety feature is not working correctly. This safety feature must work properly before proceeding with regular operations. Call Tech Support for help.

Operation Overview

The purpose of this overview is to provide the novice machine operator with a basic understanding of how the machine is used during operation, so they can more easily understand the controls discussed later in this manual.

Note: Due to the generic nature of this overview, it is not intended to be an instructional guide for performing actual machine operations. To learn more about specific operations and machining techniques, seek training from people experienced with this type of machine, and do additional research outside of this manual by reading "how-to" books, trade magazines, or websites.

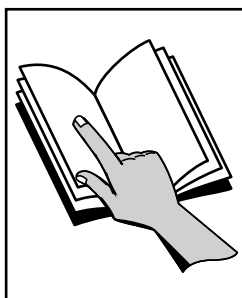

!WARNING

To reduce the risk of serious injury when using this machine, read and understand this entire manual before beginning any operations.

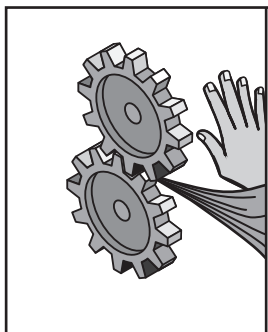

!WARNING

Loose hair, clothing, or jewelry could get caught in machinery and cause serious personal injury. Keep these items away from moving parts at all times to reduce this risk.

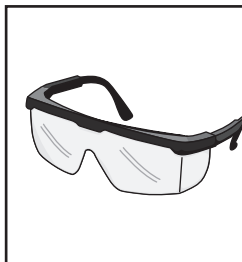

!WARNING

During operation, small metal chips may become airborne, leading to serious eye injury. Wear safety glasses to reduce this risk.

To complete a typical operation, the operator does the following:

1. Examines the grinding wheel to make sure it is suitable for use (has no visible cracks or large chips).
 2. Examines the workpiece to make sure it is prepared for grinding.
 3. Uses the elevation handwheel to raise the grinding wheel assembly to provide clearance when mounting the workpiece.
 4. Wipes the table surface clean to remove any debris that may interfere with the clamping process.
 5. Uses a magnetic chuck to hold the workpiece to the table, then turns the elevation handwheel to lower the grinding wheel to just above the top surface of the workpiece.
 6. Turns the grinder **ON**, then stands to the side of the wheel path while the wheel reaches full speed.
 7. Performs the grinding operation.
- Note:** Because the method for performing each grinding operation varies, specific actions are not listed here.
8. When the grinding operation is complete, turns the machine **OFF** and allows the grinding wheel to come to a complete stop.
 9. Removes the workpiece from the table.

Controls

Refer to **Figures 16–18** and the following descriptions to become familiar with the basic controls of this machine.

- A. Longitudinal Travel Handwheel:** Moves the table back and forth on the longitudinal axis (X-Axis).
- B. Center Table Stop:** Provides a barrier for the table stops to limit table movement.
- C. Table Stops:** Adjust along the length of the table to limit longitudinal travel.
- D. Cross Axis Lock Knob:** Locks the cross table movement.
- E. Elevation Handwheel:** Controls vertical movement (Z-Axis) of the grinding wheel assembly.
- F. Cross Travel Handwheel:** Moves the table forward and backward along the cross axis (Y-Axis).

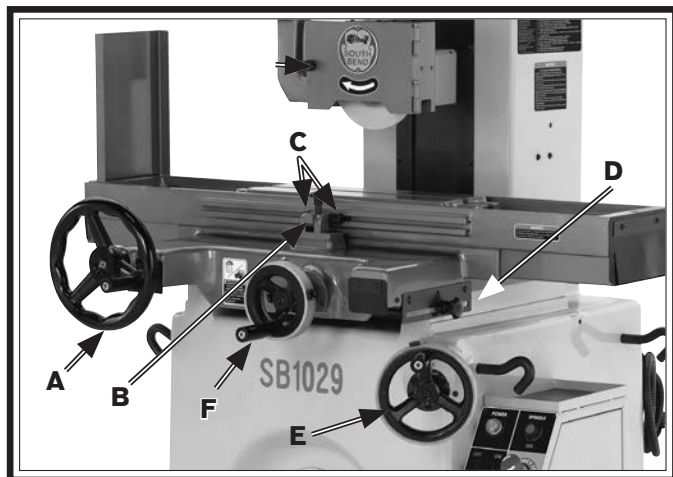

Figure 16. Basic controls.

- G. Power Indicator Light:** Illuminates when the grinding wheel motor is running.
- H. Power On Button:** Supplies power to the grinding wheel motor.
- I. Emergency Stop (Off) Button:** Cuts power to the grinding wheel motor.
- J. Coolant Pump Switch:** Control switch for the optional coolant pump accessory.

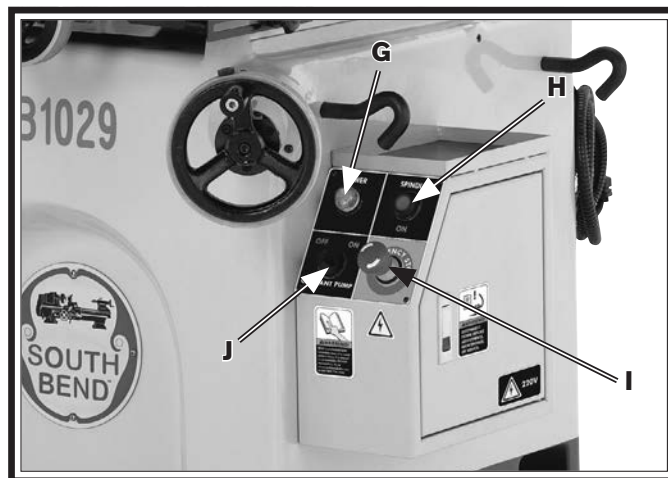

Figure 17. Control panel.

- K. Port Lock Knob:** Locks the dust port into position so it can be vertically positioned in the spark path.

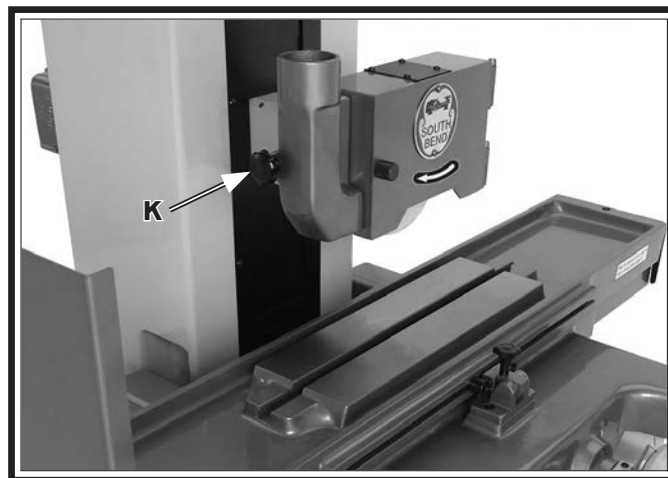

Figure 18. Port lock knob.

Wheel Selection

Most grinding wheels from major manufacturers are marked in a somewhat uniform manner. Understanding these markings will help you understand the capabilities of various wheels. Always refer to the manufacturer's grinding recommendations when selecting a wheel for your project.

The grinding wheel you choose will depend on several factors related to the operation you plan to perform. The hardness of the material you will be grinding and the surface finish you desire are the two primary factors to consider when selecting a grinding wheel.

An example of the basic format for wheel numbering is shown below. The wheel in this example is a "36A60LV".

Prefix	Abrasive Type	Grit Size	Grade	Bond Type
36	A	60	L	V

The prefix is a manufacturer-specific designation and will vary depending on the manufacturer.

Use the charts below as a basic wheel selection outline for most grinding operations.

Abrasive Type

Abrasive Type	Application
A	Aluminum Oxide: For grinding common steel.
WA	White Aluminum Oxide: For grinding harder metals (heat treated steel, carbon steel, alloy steel, etc.).
H	For grinding high speed steel.
C	Silicon Carbide: For grinding cast iron and non-ferrous metals.
CG	Ceramic Grain: For extremely hard metals, such as tungsten carbide.

Grit Size

The ideal grit for an operation depends on a number of considerations. Use the table below to choose a grit suitable for your desired results.

Operation Consideration	Results	
	Coarse Grit (10–46)	Fine Grit (54–180)
Material Removal	Increased	Decreased
Surface Finish	Rough	Smooth
Workpiece Hardness	Soft	Hard
Width of Cut	Wide	Narrow

Grade

The grade of a wheel is an indicator of its hardness based on an alphabetical scale in which A is the softest and Z is the hardest.

Operation Consideration	Wheel Hardness	
	Soft A–M	Hard N–Z
Workpiece Hardness	Hard	Soft
Width of Cut	Wide	Narrow
Feed Rate	Slow	Fast
Wheel Speed	Fast	Slow

Wheel Inspection

Do not assume that a wheel is in sound condition just because it is new—damage can often occur during shipping, with age, with prolonged exposure to moisture, or because of improper storage.

To inspect a wheel for damage:

1. Remove the wheel and look for any cracks, chips, nicks or dents in the surface of the wheel. If you see any of these, **DO NOT** attempt to use the wheel.
2. Do a ring test. This test will give you an indication of any internal damage that may not be obvious during a visual inspection.
3. Inspect the paper washers on both sides of the grinding wheel (see **Figure 19**). These washers are cushions between the spacer washer and the grinding wheel seat. Without the washers, cracks can be spawned from the center of the wheel when the spanner nut is tightened. Over time, these cracks can radiate outward and the wheel may explode during operation, possibly causing injury.



Figure 19. Important paper washer.

Note: If you need to replace or install new paper washers, replacements can be cut out of any thick construction paper or card stock. Regular notebook paper or paper from a copy machine is not acceptable, as it is too thin to provide the required cushion. Be sure to transfer any RPM limitations and wheel type information.

Ring Test

This test will give you an indication of any internal damage that may not be obvious during a visual inspection.

To perform a ring test:

1. Make sure the wheel is clean and dry; otherwise, you may get false results.
2. Hang the wheel in the air with a piece of cord or string looped through the hole in the center, as shown in **Figure 20**.

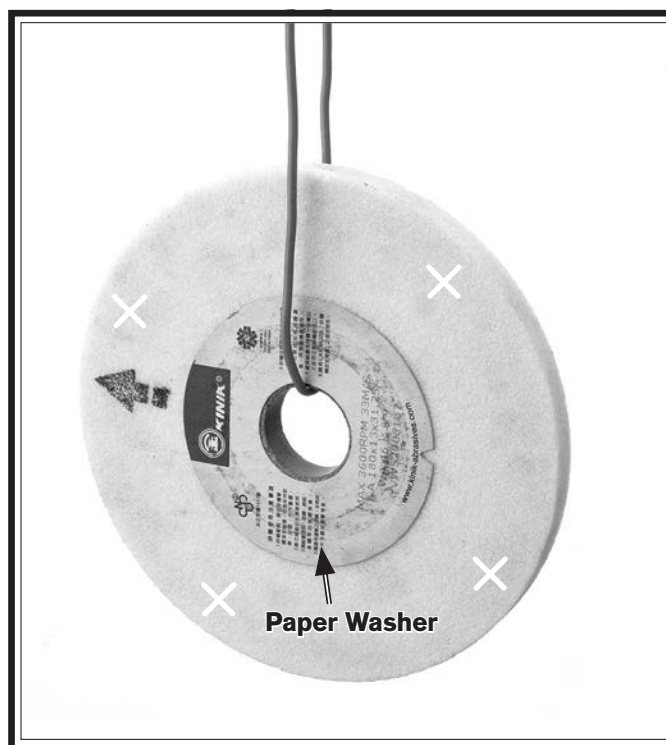

Figure 20. Ring test setup and test locations.

3. At the locations shown in **Figure 20**, gently tap the wheel with a light non-metallic device such as the handle of a screwdriver or a wooden mallet.

An undamaged wheel will emit a clear metallic ring or “ping” sound in each of these spots. A damaged wheel will respond with a dull thud that has no clear tone. If you determine from the ring test that the wheel is damaged, **DO NOT** use it!

Removing & Installing Grinding Wheels

If installing a grinding wheel for the first time, or when replacing a worn wheel, this section explains the order in which this process must take place. Every time a grinding wheel is removed from its hub, this procedure must be repeated. If installing a new wheel right out of the box, the ring (**Page 23**) test must also still be completed.

To remove and install a grinding wheel:

1. DISCONNECT MACHINE FROM POWER!
2. Place a sheet of plywood or similar on top of the table (see **Figure 21**), and open the grinding wheel cover.

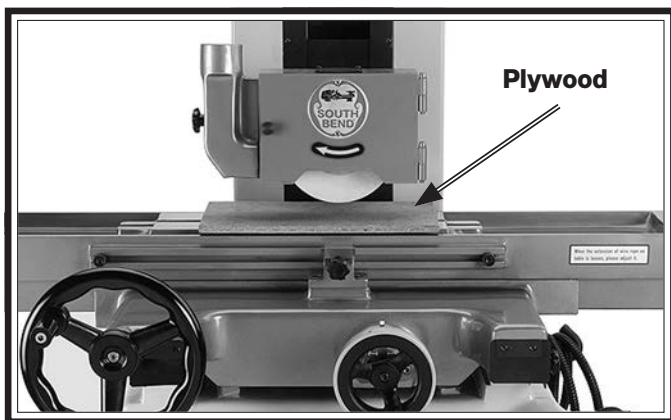

Figure 21. Protecting table.

3. Position the spindle wrenches on the spindle lug and the retaining nut (see **Figure 22**).

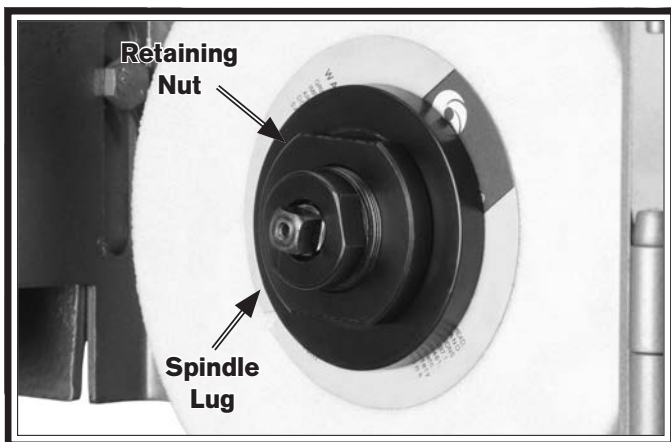

Figure 22. Wheel retaining nut.

4. Using the wrenches, loosen the retaining nut in the direction shown in **Figure 23**.

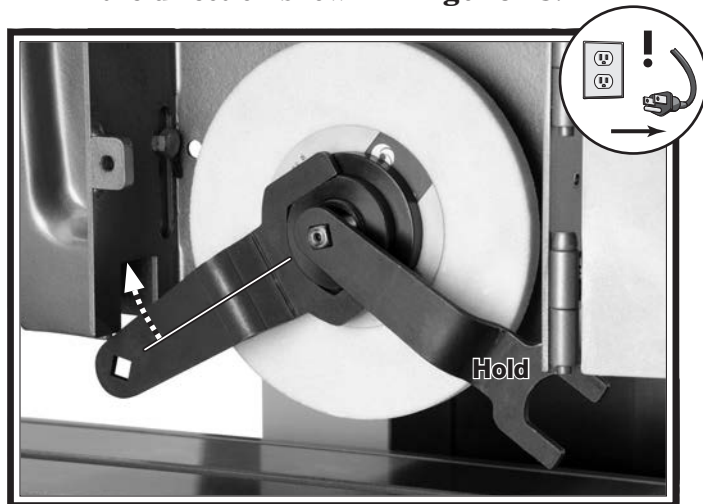

Figure 23. Removing wheel retaining nut.

5. Unthread the retaining nut (see **Figure 24**).



Figure 24. Exposing wheel retaining washer.

6. Remove the retaining washer shown in **Figure 25**.



Figure 25. Wheel ready for removal.

7. Wipe the grinding wheel seat shown in **Figure 26**, so it is perfectly clean, and no paper is left behind.

Note: A slight wiping of the spindle threads, grinding wheel seat, and hub with a lightly-oiled rag is acceptable to prevent rust.

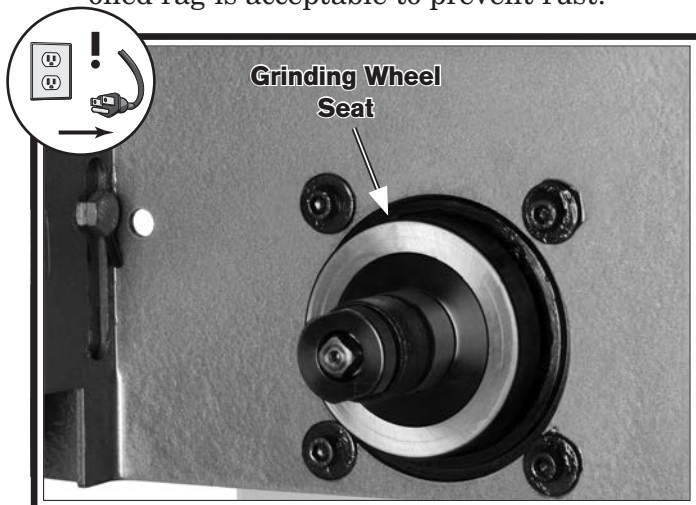

Figure 26. Wheel mounting hub.

8. Inspect for the paper washers on both sides of the grinding wheel (see **Figure 27**). These paper washers serve as cushions between the retaining washer and the grinding wheel seat. Without the washers, cracks can be spawned from the center of the wheel when the retaining nut is tightened. Over time, these cracks can radiate outward and the wheel may explode causing possible injury.

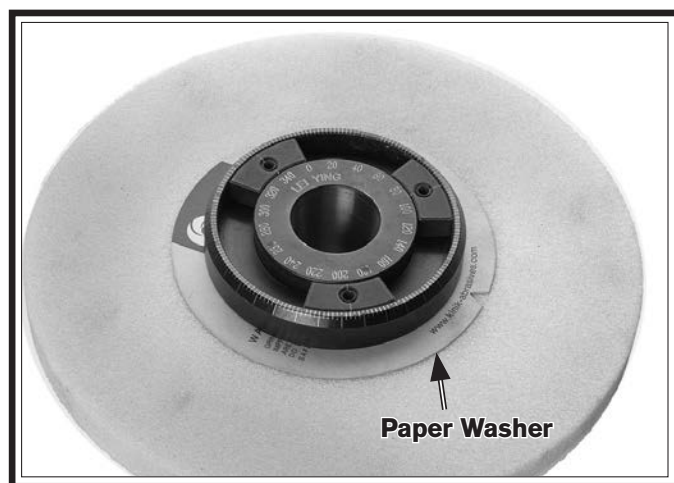

Figure 27. Important paper washer.

Note: If you need to replace or install new paper washers, replacements can be cut out of any thick construction paper or card stock. Regular notebook paper or paper from a copy machine is not acceptable as it is too thin to provide the required cushion.

9. Ring test the grinding wheel, even if it is new. If the wheel is free of cracks, slide the wheel onto the hub. Refer to **Ring Test** on **Page 23** for details.
10. Complete the preceding steps in the reverse order to install the grinding wheel, then use the grinding wheel dressing tool to true-up the wheel. Refer to **Wheel Dressing** on **Page 28** for details.
- After wheel dressing, the hub and grinding wheel must be removed as an assembly and balanced. Only after that will the wheel be able to deliver superior grinding results. Refer to **Removing & Installing Wheel & Hub** on **Page 26** to remove the assembly, and refer to **Wheel Balancing** on **Page 29** for specific procedures on balancing.

Removing & Installing Wheel & Hub

The procedure in this section describes how to install or swap one or more pre-balanced grinding wheel and hub assemblies. Having a selection of pre-balanced grinding wheel and hub assemblies on the shelf ready to go increases productivity if different grinding wheel profiles must be use during a grinding project.

To remove and reinstall the wheel and hub:

1. DISCONNECT MACHINE FROM POWER!
2. Place a sheet of plywood on top of table to protect it, as shown in **Figure 28**, and open the grinding wheel cover.

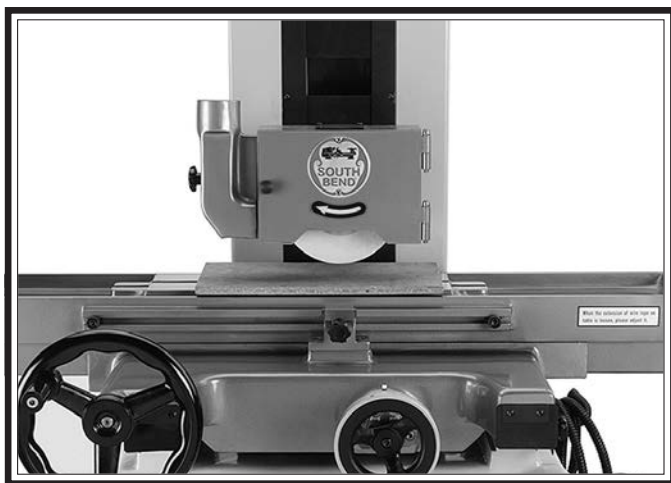

Figure 28. Protecting the table.

3. Position the spindle wrenches on the spindle lug and the barrel nut (see **Figure 29**).

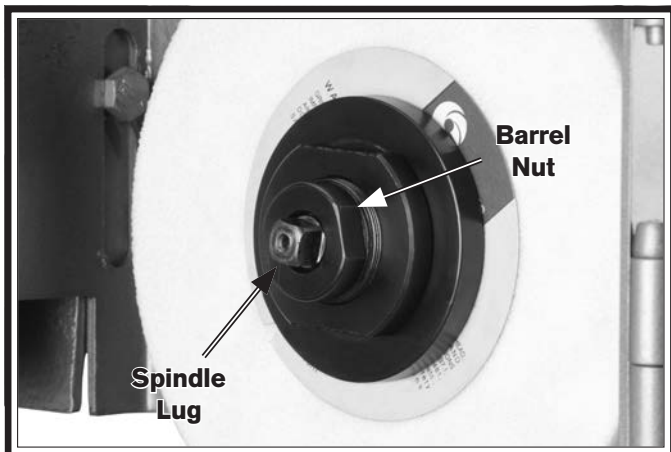

Figure 29. Component identification.

4. Loosen the barrel nut in the direction shown in **Figure 30**.

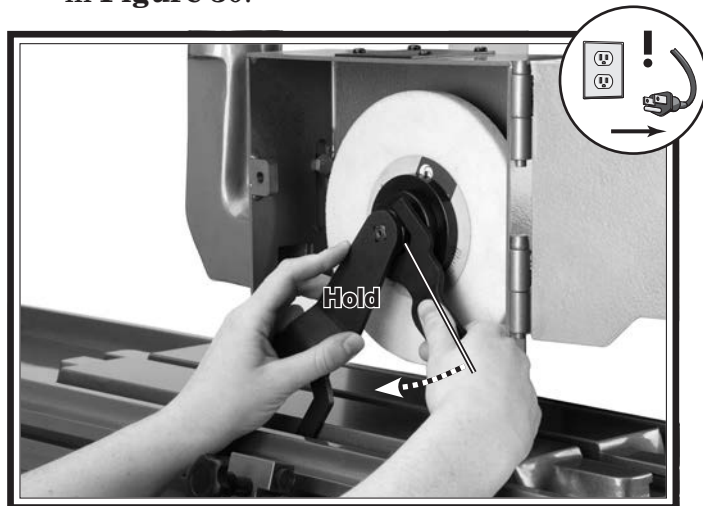

Figure 30. Hub removal.

5. Remove the barrel nut (see **Figure 31**).



Figure 31. Barrel nut removal.

6. Oil the threads and thread the hub puller (see **Figure 32**) into the hub until it stops.

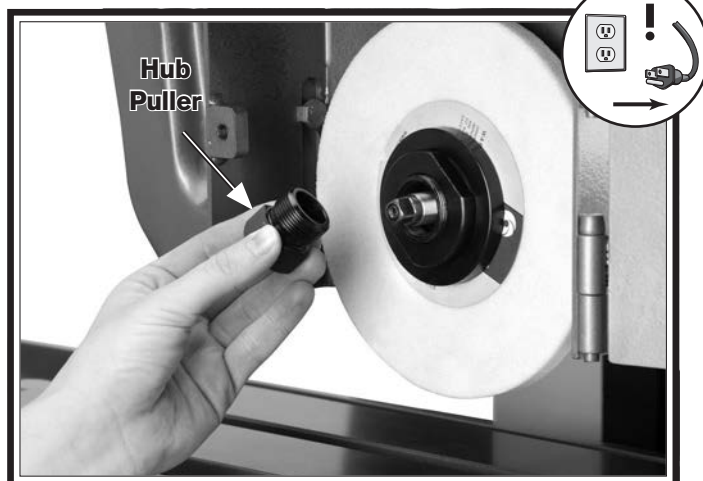

Figure 32. Hub puller installation.

7. While holding the wheel and hub from sliding off of the spindle, use the wrenches shown in **Figure 33**, tighten the hub puller until the wheel and hub assembly is pulled from the spindle.

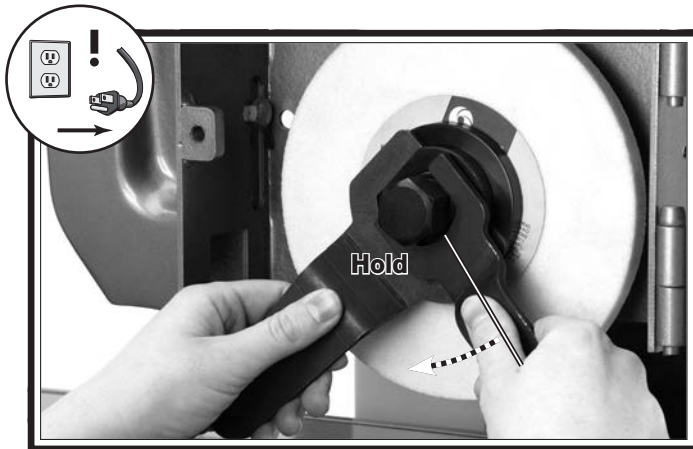

Figure 33. Pulling wheel hub.

8. Set the wrenches aside and carefully remove the wheel and hub assembly with the hub puller still installed (see **Figure 34**).

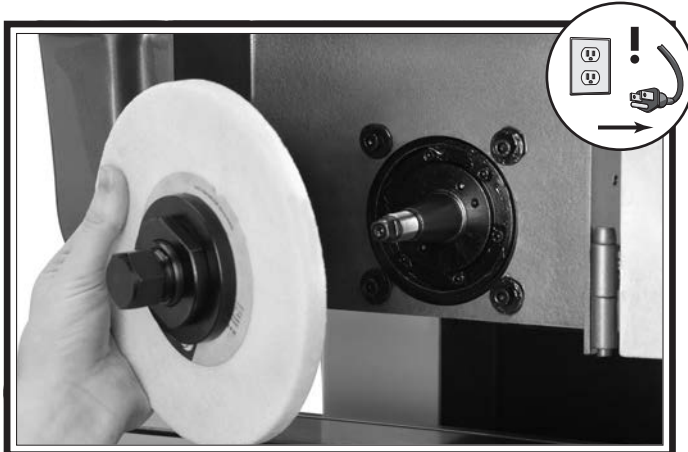

Figure 34. Wheel and hub removal.

9. Unthread the hub puller and set it aside.
10. Wipe the spindle threads, the spindle, and the hub tapers (see **Figures 35–36**) so they are perfectly clean. Wiping the threads and taper with a lightly-oiled rag to prevent rust and still to allow for a tight fit.

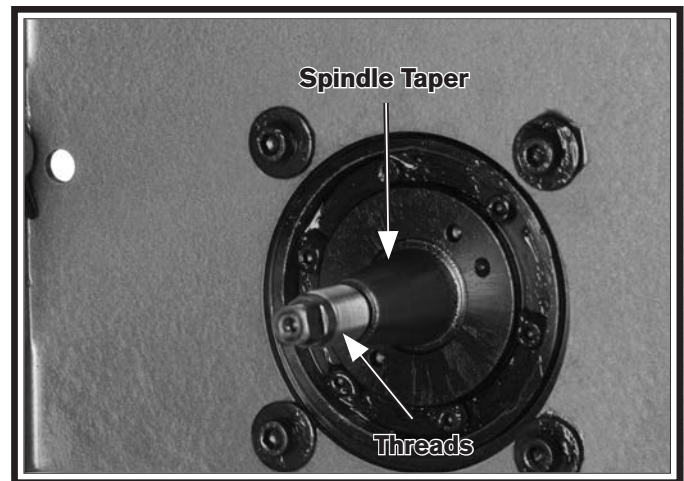

Figure 35. Spindle taper.

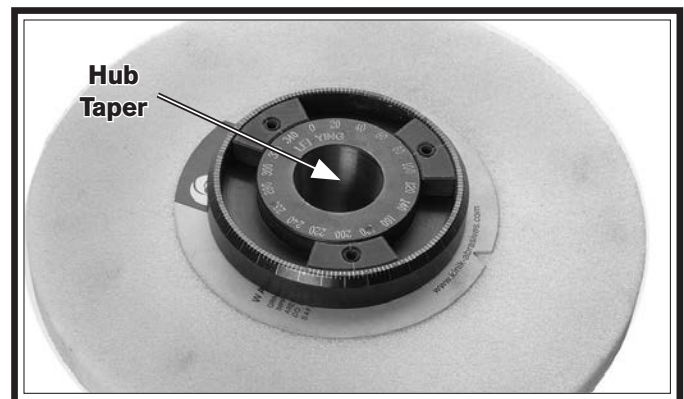

Figure 36. Wheel hub taper.

11. To install the grinding wheel and hub, wipe the tapered surfaces clean, un-thread the hub puller, and install the hub, retainer, and nut. After the grinding wheel and hub are installed, many machinists still choose to dress the grinding wheel. Refer to **Wheel Dressing** on **Page 28** for details.

Wheel Dressing

Superior grinding results can only be achieved with a properly balanced and dressed wheel. Do not assume that a wheel will run true on the spindle if it is new or has not been separated from the hub.

Dressing the wheel correctly will save you from wasting grinding abrasive and shattering the dressing tool diamond. Additionally, with a properly balanced and dressed wheel you can rest assured that if you have finish problems, the grinding wheel will not be the culprit.

Depending on the finish required, varying degrees of roughness can be obtained. For example: A fast dressing at a depth of 0.03mm will prepare a wheel surface for rough cuts, and slow dressing with multiple light passes at a depth of 0.01mm will prepare the same wheel for finish cuts.

Positioning is critical for the dressing tool so you will not shatter the diamond or have poor results. For best results and safe use, the dressing tool must be positioned in the trailing zone of the wheel, as shown in **Figure 37**. If the tool is positioned on the leading side of the wheel, the diamond will be shattered or even grabbed by the wheel and drawn under the grinding wheel, causing severe injury or property damage.

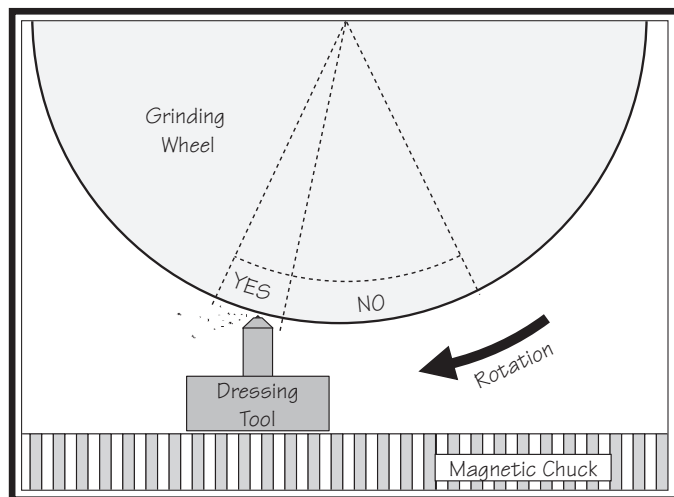

Figure 37. Safe tool positioning for wheel dressing.

To dress the grinding wheel:

1. Insert the diamond-tipped dressing tool into its base (see **Figure 38**), and use a 4mm hex wrench to tighten the locking set screw.



Figure 38. Dressing tool setup.

2. Lower the headstock so the wheel is approximately 5mm lower than the tip of the dressing tool.
3. Position the tip of the dressing tool at the trailing side of the wheel, as shown in **Figure 37**, and move the table inward until the diamond tip slightly touches the edge of the grinding wheel. Verify by rotating the wheel by hand and listening for contact.
4. Apply the magnetic chuck, and move the cross slide so the diamond tip is free of the grinding wheel.
5. Start the grinder, and use the cross slide handwheel to progressively move the table so the diamond sweeps across the wheel at a depth between 0.01 – 0.03mm.

Wheel Balancing

Static wheel balancing can be difficult and very time consuming without practice. For accurate grinding results, wheel balancing is mandatory. For this balancing procedure, you will need a wheel balancing fixture. The wheel balancing fixture shown in **Figure 39** is one example of the many varieties available on the market. Before proceeding, the grinding wheel must be ring tested (refer to **Page 23**) and dressed (refer to **Page 28**).



Figure 39. Wheel on balancing fixture.

If flood coolant was used with the grinding wheel, run the machine with the grinding wheel installed for 5-minutes to sling off any residual coolant that may have settled to the low side of the wheel. If the paper washers are missing, wet, or damaged, replace them before proceeding. If, during a period of machine operation, you find that a finish is becoming poor, redress the wheel. If that does not correct the problem, rebalance your grinding wheel.

To balance the grinding wheel:

1. DISCONNECT MACHINE FROM POWER!
2. Set up the wheel balancer as outlined in its product user manual.
3. Remove the grinding wheel and hub as a unit from the spindle as outlined in **Removing & Installing Grinding Wheel Hub** on **Page 26**.

4. Without letting any of the balance dogs or lock balls fall out of the hub, use a 2.5mm hex wrench to loosen the dogs and position them at the 0°, 120°, and 240° degree locations indicated by the degree scale on the hub (see **Figure 40**).

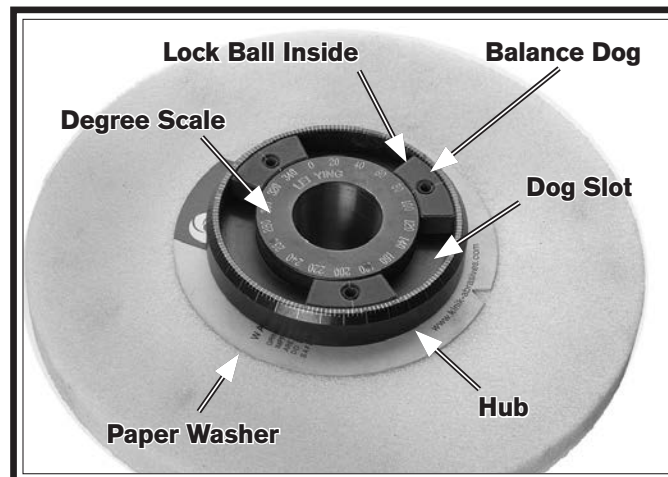

Figure 40. Grinding wheel hub.

Note: Pay special attention to keep the dogs engaged in the hub slot when they are loose. If you lose any of the lock balls, it will be impossible to continue this procedure until they are replaced.

5. Using a slightly-oiled lint free cloth, wipe the mating surfaces of the balancing arbor and the internal hub taper perfectly clean, then push them together, as shown in **Figure 41**.

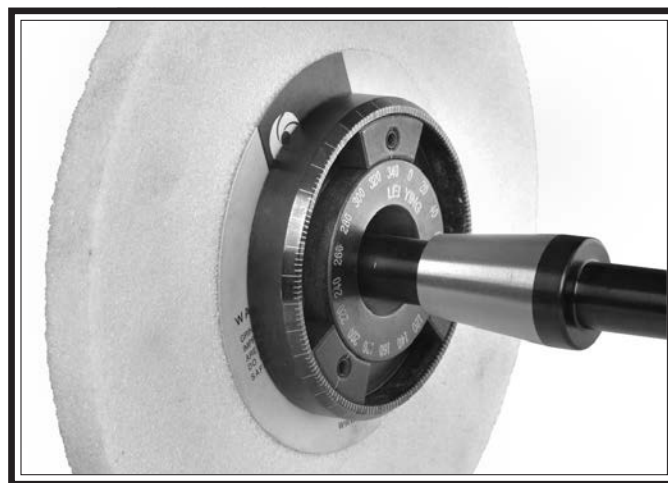

Figure 41. Installing the balancing arbor.

6. Place the balancing arbor onto the wheel balancing fixture (**Figure 39**).

7. Spin the wheel so it rotates one full turn and comes to rest with the heaviest side hanging down at six O'clock. This may take a few times to find the exact location.
 8. Using a pencil, draw a line on the wheel at the six O'clock position to mark the heaviest side.
 9. Line up the closest dog with the line you just drew and lock it in place. This dog will now be positioned at the heaviest side of the wheel and will be called dog "A".
 10. Using the scale as a guide, position the other two "B" dogs so they are both evenly spaced 120° degrees apart from the "A" dog. At this point, all dogs will be 120° apart from one another. "B" dogs will be the two dogs that will be moved to balance out the location that is out of balance.
 11. Rotate the wheel to 90° degrees and release it to observe the direction that the wheel rotates out of balance. Move each "B" dog toward one another and away from dog "A" in 1° degree increments to balance out the wheel.

For example: depending on the amount of balance correction, the distance between the two "B" dogs will decrease, and the distance between the "B" dogs and "A" dog will increase. This step must be repeated as many times as required until the wheel will not rock back and forth by itself the heavy spot.
 12. When you are satisfied with the wheel balance settings, install the grinding wheel on the machine, and test run for five minutes to verify the balance. If any problems are detected, repeat the balancing procedure.
- Note:** Some machinists will re-dress the grinding wheel one last time at this point to ensure ultra-precision grinding results.

Magnetic Chuck

The Model SB1029 table is equipped with a T-slot for securing a magnetic chuck. Refer to the magnetic chuck manufacturer's instruction manual for proper preparation and mounting techniques.

A magnetic chuck secures workpieces to the table without the use of clamps. With proper attention to preparation of both the workpiece and the magnetic chuck, a magnetic chuck will provide ample clamping force on most magnetic metals.

Dust Port Positioning

The Model SB1029 has a dust port to gather waste material created during grinding. The dust port is vertically adjustable so that it can be positioned directly in the path of the sparks.

To adjust the dust port position:

1. Hold the dust port with one hand to prevent it from moving, then loosen the lock knob shown in **Figure 42**.

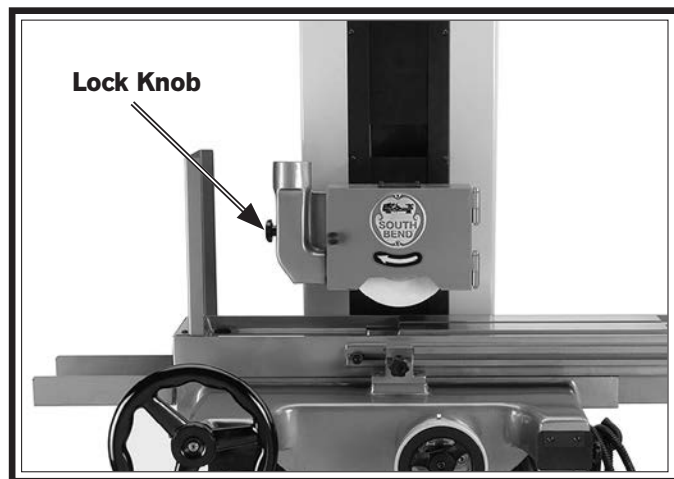

Figure 42. Dust port lock knob.

2. Position the dust port as needed, then re-tighten the lock knob.

Setup for a Typical Grinding Operation

Once you have chosen the proper wheel for the operation and properly installed the magnetic chuck on the table, use the following procedures to prepare for a grinding operation.

To prepare for a grinding operation:

1. **DISCONNECT MACHINE FROM POWER!**
2. To ensure flat mating surfaces on the workpiece and the magnetic chuck, surface grind and stone the top of the chuck and the bottom of the workpiece. Clean all surfaces to make sure they are free of contaminants.
3. Make sure the magnetic chuck is turned **OFF**, then place the workpiece onto the chuck. Once the workpiece is positioned as needed, turn the magnetic chuck **ON**.
4. Make sure the grinding wheel is not contacting the workpiece, connect the grinder to power, then turn the motor **ON**.

Grinder Operation

Grinding with a surface grinder is a delicate process that takes practice, skill, and knowledge. In addition to this, the method used for any one procedure will depend on a number of factors, including, but not limited to the material being ground, the grinding wheel being used, the quality and calibration of measuring tools, and the finish that is desired.

For these reasons, specific techniques are not outlined in this manual. We recommend that you consult books, trade magazines, metalworking experts, and other reliable resources for techniques pertaining to the specific tasks you wish to perform.

The information that follows serves as a general outline to help familiarize you with the basic grinding technique.

Using the Surface Grinder

Operation of the grinder is controlled through the movement of the three handwheels. The elevation handwheel controls the up and down movement of the grinding head. It is this axis that governs the amount of stock removal. Never attempt to remove too much material in one pass. The best results are achieved with multiple light passes.

The longitudinal travel handwheel rapidly moves the table from left to right. This allows the operator to move the workpiece back and forth underneath the grinding wheel.

The cross travel handwheel controls the front-to-back movement of the table and is only to be used between longitudinal passes to expose a new area of the workpiece to the grinding wheel. Slightly overlap passes to ensure complete coverage.

When grinding, sweep the table back and forth under the wheel in the longitudinal direction until no further sparks emerge from the workpiece, move the table in the cross direction to expose a new portion of the workpiece to the wheel, then take another sweep in the longitudinal direction. Repeat this process until the entire surface is ground. See **Figure 43** for an illustration of this process.

Grinding Tips

While every grinding operation is unique, there are a few techniques that apply to most, if not all grinding operations.

- During longitudinal passes, tighten the cross travel lock knob to prevent chatter that may occur as a result of slight cross movement of the table.
- Between longitudinal passes, use the squeegee to remove any foreign material from the workpiece.
- After an initial pass, adjust the dust port to be directly in the path of the sparks to minimize the amount of waste material ejected into the work space.

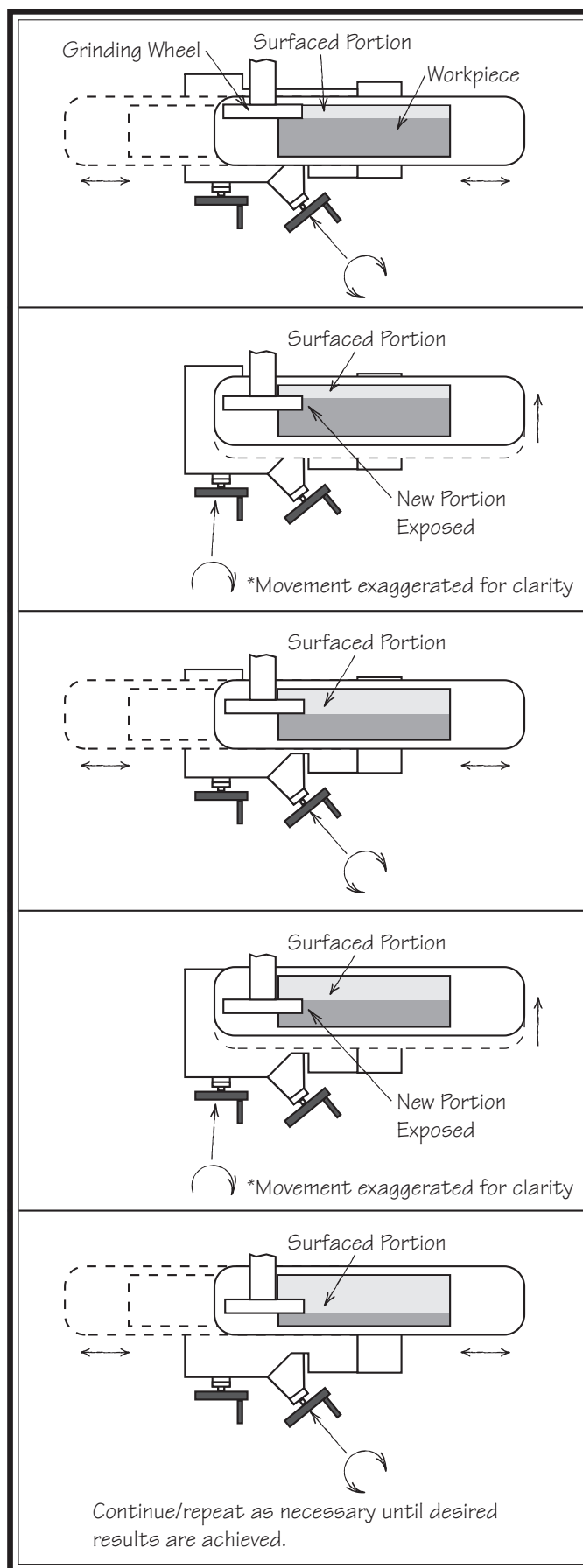
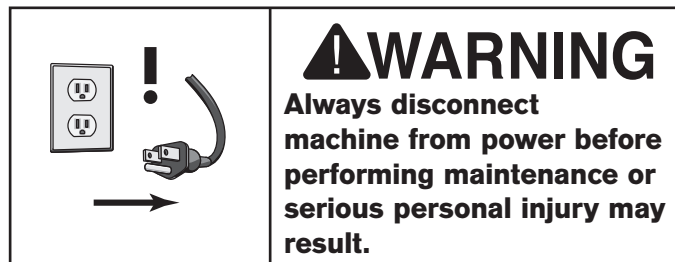

Figure 43. Grinding process illustrated.

Maintenance Schedule Basic Lubrication



Recommended Lubricating Oil Types:

To avoid oil breakdown, DO NOT MIX OILS! If changing oil types, be sure to flush system with the new oil and discard the flushed oil.

- Mobil Vacuoline 1405
- Mobil Vacuoline 1409
- Shell Tonna 33
- Shell Tonna 27
- BP Energol HP 20-C

Daily:

- Check/correct loose mounting bolts.
- Check/correct damaged or cracked grinding wheel.
- Check/correct worn or damaged wires.
- Clean/protect table.
- Vacuum metal shavings from machine.
- Correct any other unsafe condition.

Bi-Annually:

- Change lubrication oil, verify oil distribution setting.
- Clean and re-oil pinion gears.

Annually:

- Remove pump screen and clean debris.
- Verify machine is level and readjust as required.

If this machine is used in a heavy industrial setting, or in a dirty or damp environment, increase the oil-change intervals.

If the machine is new or being put back into service from storage, you must first to flush the lubrication system with ATF Dextron II. Run the pump for 5-10 minutes, and move all handwheels through their full range of motion as the high detergent oil breaks down and flushes away storage grease from the bearings, ways, and galleys. When finished, drain and refill the oil system, and conduct a test run as outlined in this manual.

To lubricate your machine:

1. Read and take the appropriate safety measures covered in this manual.
2. Remove the screws and the left-side cabinet access plate, and fill the oil reservoir or replace the oil if it is dirty (see **Figure 44**).

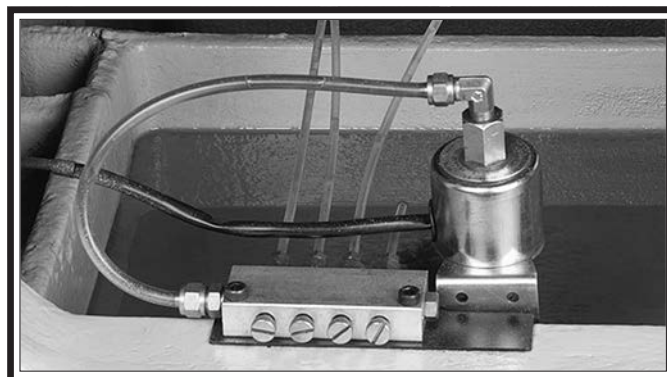

Figure 44. Lubrication pump and reservoir.

3. Make sure the pinion gears and leadscrew (**Figure 45**) are wet with oil.

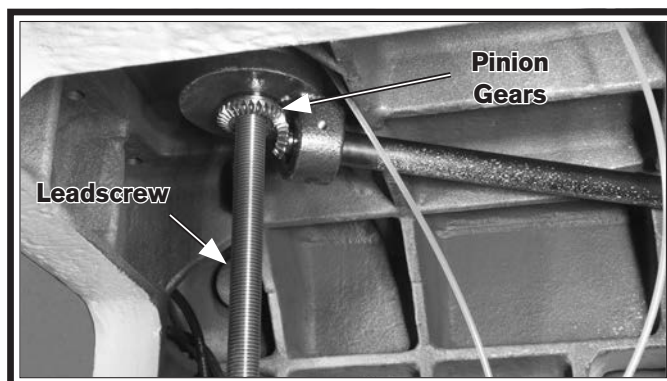

Figure 45. Lower leadscrew and pinion gears.

- If the pinions or leadscrew show a buildup of contaminants, clean them with mineral spirits and re-oil.
 - If the pinions or leadscrew are dry, verify that the pump screen is clean, and adjust the oil distribution screw to increase lubrication.
4. At the rear of the column, slide the column dust shield upward and inspect the upper leadscrew (see **Figure 46**).



Figure 46. Upper leadscrew inspection.

- If the leadscrew has a buildup of contaminants, clean it with mineral spirits and re-oil.
 - If the leadscrew is dry, verify that the pump screen is clean, and adjust the oil distribution screw to increase lubrication.
5. Using a rust preventative oil, wipe down all bare metal surfaces.
6. Using any quality automotive paint cleaner and wax, clean and wax all painted surfaces.

Changing Oil & Adjusting Oil Flow

This machine is equipped with a pressurized constant-flow oiling system where the oil returns back to the reservoir through oil galley drillings in the machine castings. Once oil is returned back to the reservoir, the oil is then filtered through a mesh screen and pumped back into the machine.

In heavy industrial or dirty environments, change this oil more frequently. To avoid oil breakdown, **DO NOT MIX OILS!** If changing oil types, be sure to flush the system with the new oil and discard the flushed oil.

Recommended Oils:

- Mobil Vacuoline 1405
- Mobil Vacuoline 1409
- Shell Tonna 33
- Shell Tonna 27
- BP Energol HP 20-C

To change the oil and adjust the flow rate:

1. DISCONNECT MACHINE FROM POWER.
2. Remove the panel from the rear of the cabinet.
3. Using a standard screwdriver, turn number #1, #2 and #3 needle valves (see **Figure 47**) clockwise to the closed position. **DO NOT OVERTIGHTEN.**

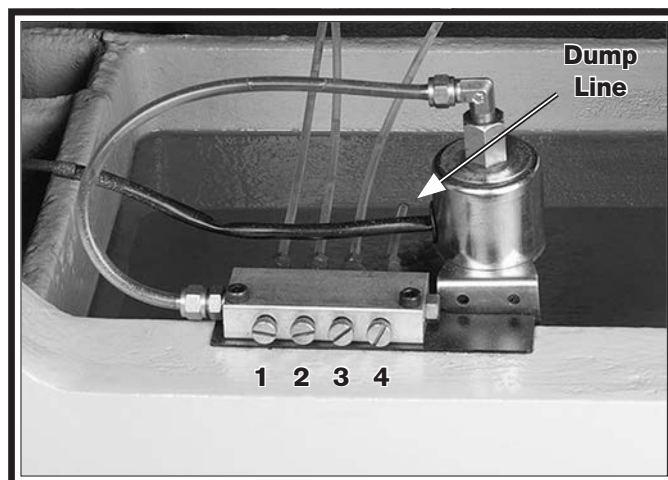

Figure 47. Oil pump and reservoir.

4. Close needle valve #4 (see **Figure 47**), and then open it three full turns.
5. Place a waste oil container under the dump line (see **Figure 47**), and turn the pump on. The waste oil will be pumped into the waste oil container. When the reservoir is empty, wipe the reservoir out with clean rags.
6. Using a 4mm hex wrench, remove the pump mounting screws and the pump.
7. Invert the pump and inspect the suction screen (see **Figure 48**). Clean the screen with mineral spirits as required to ensure full flow.

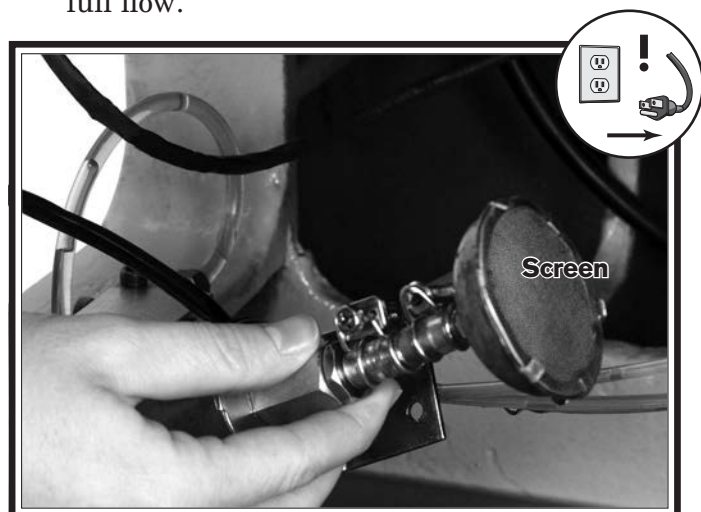

Figure 48. Oil pump screen.

8. Reinstall the pump and add 5-quarts of oil.
9. Back-out needle valves #1, #2 and #3 ¼-turn.
10. Turn the pump **ON**. *Next* turn the pressure needle valve #4 inward until it is fully seated.
11. Unscrew needle valve #4 slowly until three drops a second of oil are seen returning to the reservoir from the port directly above the reservoir and left of the leadscrew.
12. Reinstall the cover.

Removing Table Backlash

Longitudinal table travel is controlled by a handwheel connected to a cable and a set of pulleys, which in turn are connected to the table. Through time, the cable may stretch slightly. When this occurs, table/handwheel backlash will be detected. To remove this backlash, a simple adjustment can be made.

To remove table backlash:

1. Turn the oil pump ON for a few minutes to lubricate the ways.
2. Move the table from left and right a few times to distribute the oil.
3. Select a pulley at either end of the table, and loosen the pulley cap screw (see **Figure 49**) with a 6mm hex wrench, raise the dust skirt, and rotate the pulley clockwise until tension is felt in the cable.
4. While holding the pulley and cable tight, tighten the cap screw.



Figure 49. Adjusting cable pulley.

If you need replacement parts, or if you are unsure how to do any of the solutions given here, feel free to call us at (360) 734-1540.

Symptom	Possible Cause	Possible Solution
Machine does not start.	<ol style="list-style-type: none"> 1. No power; voltage is incorrect. 2. Blown fuse/tripped circuit breaker at main panel. 3. Plug or receptacle is corroded or mis-wired. 4. Thermal overload relay has tripped. 5. Break or short in wiring; or loose connections. 6. Motor ON/OFF switch at fault. 7. Motor connection wired incorrectly. 8. Contactor not energized/has poor contacts. 9. Motor at fault. 	<ol style="list-style-type: none"> 1. Switch power supply ON/verify and correct voltage. 2. Correct the cause of overload, then reset/replace fuse or breaker. 3. Clean/retighten contacts; correct the wiring. 4. Allow motor to cool. If necessary, press reset button inside switch. 5. Trace/replace broken or corroded wires; fix loose connections. 6. Replace switch. 7. Wire motor correctly (refer to inside junction box cover or manual). 8. Test all legs for power, test field coil and replace if at fault. 9. Test for shorted windings, bad bearings and repair or replace.
Main motor chatters during startup or during operation.	<ol style="list-style-type: none"> 1. Extension cord (if used) is causing voltage drop. 2. Phase converter (if used) wild wire connected wrong. 3. Power supply has incorrect voltage on one or more legs. 	<ol style="list-style-type: none"> 1. Move machine closer to the power source, or use a larger gauge wire or shorter extension cord. 2. Connect wild wire to the machine power supply terminal that directly feeds motor. It must not feed current to contactor field coils or the transformer. 3. Contact your power company to fix the power supply.
Machine operates in reverse.	<ol style="list-style-type: none"> 1. Power connections wired out of phase. 	<ol style="list-style-type: none"> 1. Swap two power incoming power leads.
Machine has excessive vibration or noise.	<ol style="list-style-type: none"> 1. Motor fan rubbing on fan cover. 2. Motor is loose. 3. Grinding wheel out of balance. 4. Motor bearings worn or damaged. 	<ol style="list-style-type: none"> 1. Fix/replace fan cover; replace loose or damaged fan. 2. Tighten any loose fasteners. 3. Dress and balance grinding wheel. 4. Replace motor bearings or replace motor.
Machine stalls or slows when operating.	<ol style="list-style-type: none"> 1. Motor is being overloaded. 2. Motor is wired out of phase. 3. Motor at fault. 	<ol style="list-style-type: none"> 1. Reduce depth of cut. 2. Swap two power incoming power leads. 3. Test for shorted windings, bad bearings and repair or replace.
Handwheel has excessive backlash, end play, binds, or is difficult to move.	<ol style="list-style-type: none"> 1. Leadscrew is dirty or lacks proper lubrication. 2. Longitudinal feed cable is loose. 3. Linkage bolts, pins, and holes are loose or worn. 4. Leadscrew or leadscrew nut worn. 	<ol style="list-style-type: none"> 1. Clean and lubricate the leadscrew and service oil system (Page 33). 2. Adjust longitudinal feed cable (Page 35). 3. Replace linkage bolts, pins, and re-bush any worn pin holes. 4. Replace leadscrew or leadscrew nut.

Symptom	Possible Cause	Possible Solution
Vibration when grinding, poor surface finish, or incorrect final dimensions.	<ol style="list-style-type: none"> 1. Grinding wheel is out-of-round or is loaded up with material. 2. Grinding wheel is out of balance or damaged. 3. Missing or torn grinding wheel paper washers. 4. Incorrect grinding wheel hardness or grit rating. 5. Improperly installed magnetic chuck. 6. Workpiece is loose. 7. Wheel hub not installed onto spindle shaft correctly. 8. Loose machine component. 9. Ways or leadscrews are out of lubrication or contaminants have loaded up on the ways. 10. Grinding wheel has varying densities, or is of poor quality. 11. Table and handwheel have lash. 12. Bad motor or spindle bearings. 13. Grinding operation requires coolant. 14. Coolant is incorrect or incorrectly mixed. 	<ol style="list-style-type: none"> 1. Dress grinding wheel to make concentric, and to the required grit level (Page 28). 2. Remove and ring test (Page 23), and balance the grinding wheel (Page 29). 3. Remove and replace paper washers, dress and rebalance grinding wheel. 4. Match wheel grade and grit rating with workpiece hardness. 5. Stone table and chuck surfaces, and remove all burs and foreign material from mating surfaces, and reinstall the chuck. 6. Replace or repair chuck for poor holding power. 7. Remove wheel and hub assembly, stone tapers, and reinstall wheel and hub (Page 26). 8. Inspect all machine connections, and tighten any loose fasteners. 9. Remove table, clean and relubricate the ways and ball bearings. Service oil system and readjust oil flow (Page 33). 10. Replace grinding wheel with acceptable brand (Page 24). 11. Adjust table/handwheel lash (Page 35). 12. Replace motor or replace bearings. 13. Install aftermarket coolant kit. 14. Refer to coolant manufacturers workpiece verses coolant type recommendations and correct coolant.

Machine Storage

If the machine is not properly prepared for storage, it may develop rust or corrosion. If decommissioning this machine, use the steps in this section to ensure that it remains in good condition for later use.

To prepare your machine for storage:

1. Pump out the old oil, then clean and wipe out the oil reservoir.
2. If coolant was used, put on safety goggles and clean the coolant system. Next, add a few drops of oil in the lines to prevent corrosion, and blow out the lines with compressed air.
3. **DISCONNECT MACHINE FROM POWER!**
4. Remove the grinding wheel and hub. Coat the hub tapered bore and the spindle taper with white lithium grease for protection.
5. Lubricate the machine as outlined in the Maintenance Schedule on **Page 32**, and thoroughly clean all unpainted bare metal surfaces, then apply a liberal coat of way oil.
6. Have an assistant carefully lift up on the table so it is raised approximately an inch or two, use the wires to insert each neoprene seat into its respective way (see **Figures 50–51**), then carefully lower the table onto the ball bearings. The table must be resting on the seats at all four corners.

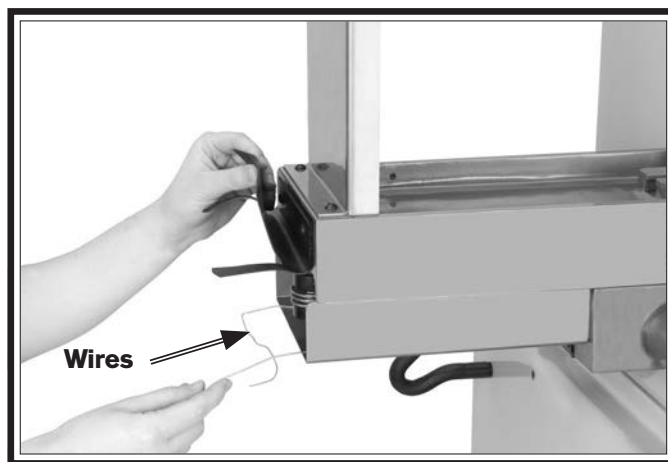

Figure 50. Neoprene shipping seat wires.

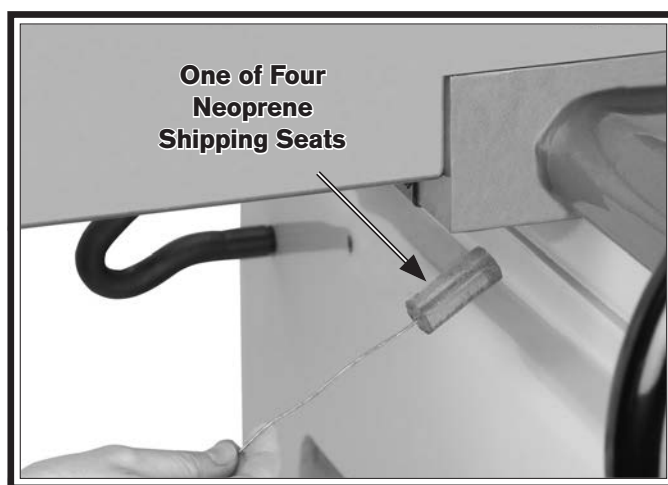

Figure 51. Neoprene shipping seat.

7. Next use a paint brush and white lithium grease to coat all bearings and ways with a coat of grease to prevent rust.
8. Place one or two moisture absorbing desiccant bags at the bottom of the electrical box.
9. Cover and place the machine in a dry area that is out of direct sunlight and away from hazardous fumes, paint, solvents, or gas. Fumes and sunlight can bleach or discolor paint and make plastic guards cloudy.

Electrical Safety Instructions

These pages are accurate at the time of printing. In the constant effort to improve, however, we may make changes to the electrical systems of future machines. Study this section carefully. If you see differences between your machine and what is shown in this section, call Technical Support at (360) 734-1540 for assistance BEFORE making any changes to the wiring on your machine.

Shock Hazard: It is extremely dangerous to perform electrical or wiring tasks while the machine is connected to the power source. Touching electrified parts will result in personal injury including but not limited to severe burns, electrocution, or death. For your own safety, disconnect machine from the power source before servicing electrical components or performing any wiring tasks!

Wire Connections: All connections must be tight to prevent wires from loosening during machine operation. Double-check all wires disconnected or connected during any wiring task to ensure tight connections.

Modifications: Using aftermarket parts or modifying the wiring beyond what is shown in the diagram may lead to unpredictable results, including serious injury or fire.

Motor Wiring: The motor wiring shown in these diagrams is current at the time of printing, but it may not match your machine. Always use the wiring diagram inside the motor junction box.

Circuit Requirements: Connecting the machine to an improperly sized circuit will greatly increase the risk of fire. To minimize this risk, only connect the machine to a power circuit that meets the minimum requirements given in this manual.

Capacitors/Inverters: Some capacitors and power inverters store an electrical charge for up to 10 minutes after being disconnected from the power source. To reduce the risk of being shocked, wait at least this long before working on capacitors.

Wire/Component Damage: Damaged wires or components increase the risk of serious personal injury, fire, or machine damage. If you notice that any wires or components are damaged while performing a wiring task, replace those wires or components before completing the task.

Experiencing Difficulties: If you are experiencing difficulties understanding the information included in this section, contact our Technical Support at (360) 734-1540.

WIRING DIAGRAM COLOR KEY

BLACK — Bk	BLUE WHITE — Bw	RED — Rd	PINK — Pk	WHITE — Wt
BLUE — Bl	GREEN — Gn	LIGHT BLUE — Lb	PURPLE — Pu	YELLOW GREEN — Yg
BROWN — Br	GRAY — Gy	ORANGE — Or	TUR-QUIOSE — Tu	YELLOW — Yl

NOTICE: The photos and diagrams included in this section are best viewed in color. You can see them in color at www.southbendlathe.com.

Rewiring for 440V

Wiring diagrams are provided in this section showing the Model SB1029 wired for both 220V and 440V. Refer to these diagrams if needed when following this procedure. Additionally, you must purchase 440V Conversion Kit (Part No. PSB1029510) in order to complete the conversion.

Hardwiring to Power Source

Hardwire setups require power supply lines to be enclosed inside of conduit that is securely mounted and constructed in adherence to applicable electrical codes.

A hardwire setup for this machine must be equipped with a locking disconnect switch as a means to disconnect the power during adjustments or maintenance, which is a typical requirement for lock-out/tag-out safety programs (commonly required by OSHA). **Figure 13** shows a simple diagram of a hardwire setup with a locking disconnect switch between the power source and the machine.

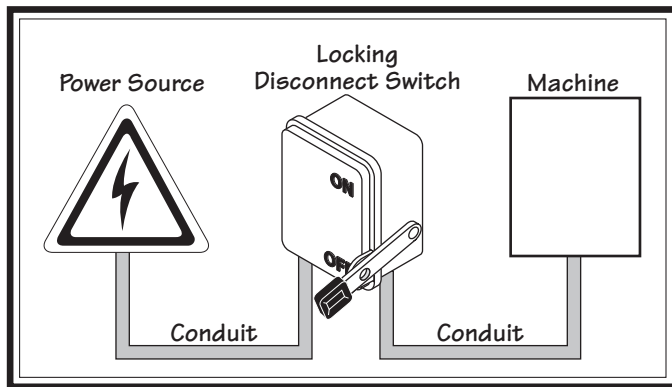

Figure 13. Typical hardwire setup with a locking disconnect switch.

Due to the complexity required for planning, bending, and installing the conduit necessary for a hardwire setup, this type of setup can only be performed by an experienced electrician.

For Electrician: Connect the incoming power wires as shown in **Figure 13**.

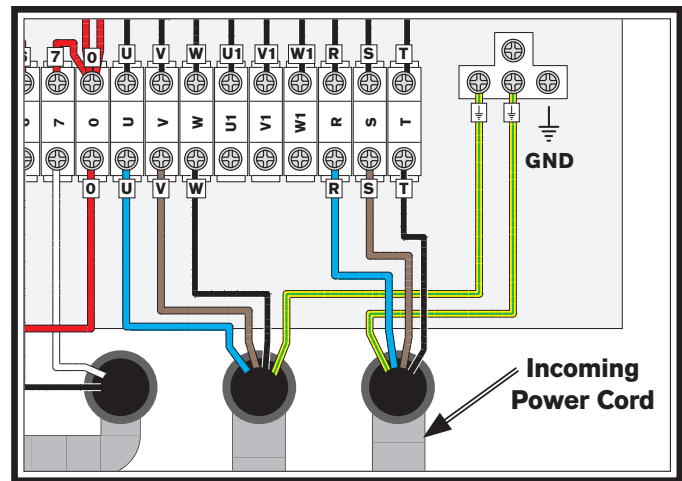

Figure 52. Power connection wiring.

Items Needed	Qty.
440V Conversion Kit (Part No. PSB1029510)	1
Phillips Screwdriver #2	1

To convert the Model SB1029 to operate on 440V:

1. DISCONNECT MACHINE FROM POWER!
2. Open the motor junction box, then loosen the nine screws that secure the wires and jumpers to the motor junction block shown in **Figure 53**.

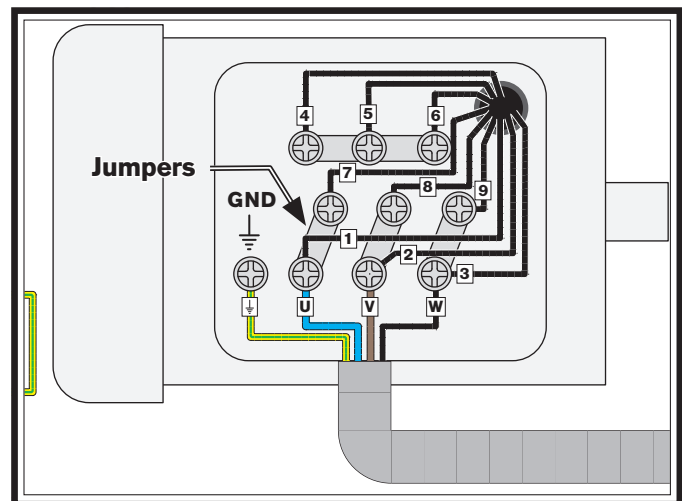

Figure 53. 220V Jumper locations.

- Without changing the location of any of the wires, reposition the jumpers as shown in **Figure 54**. Stack the jumpers as needed, since there will be two extras.

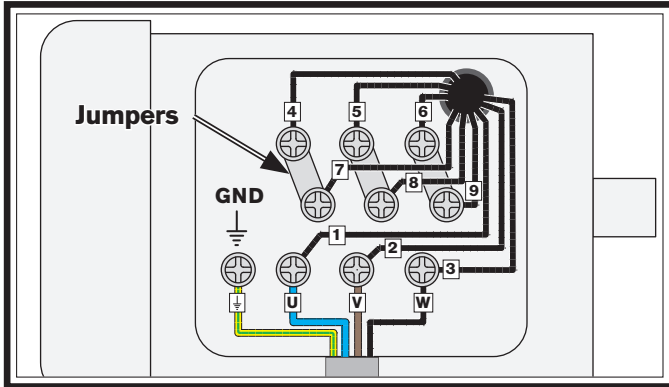

Figure 54. 440V Jumper locations.

- Tighten the nine screws that secure the wires and jumpers, making sure the wires are still located in their original positions.
- Open the electrical box on the side of the machine. Loosen all of the screws that secure the wires to the thermal relays and the screws that secure the thermal relays to the contactors (**Figure 55**). Pay careful attention to the location of the wires so you can replace them in the same position later.

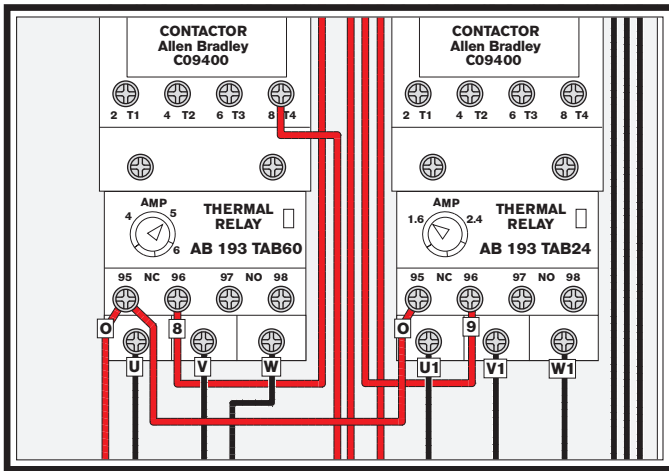

Figure 55. 220V Thermal relays.

- Replace the installed relays for the coolant pump relay and spindle motor with the relays from the 440V conversion kit, installing all of the wires in the same location from which they were removed.
- Move the "T" wire from the 220V terminal to the 440V terminal on the transformer, as shown in **Figure 56**.

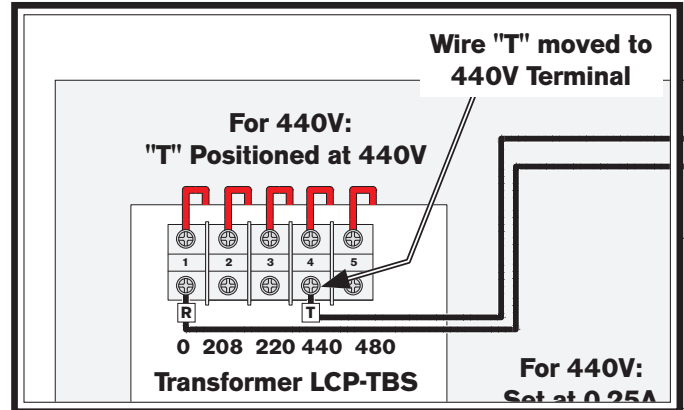

Figure 56. Wire "T" moved to 440V.

- Hardwire the machine to a 440V locking disconnect switch.



220V Electrical Components

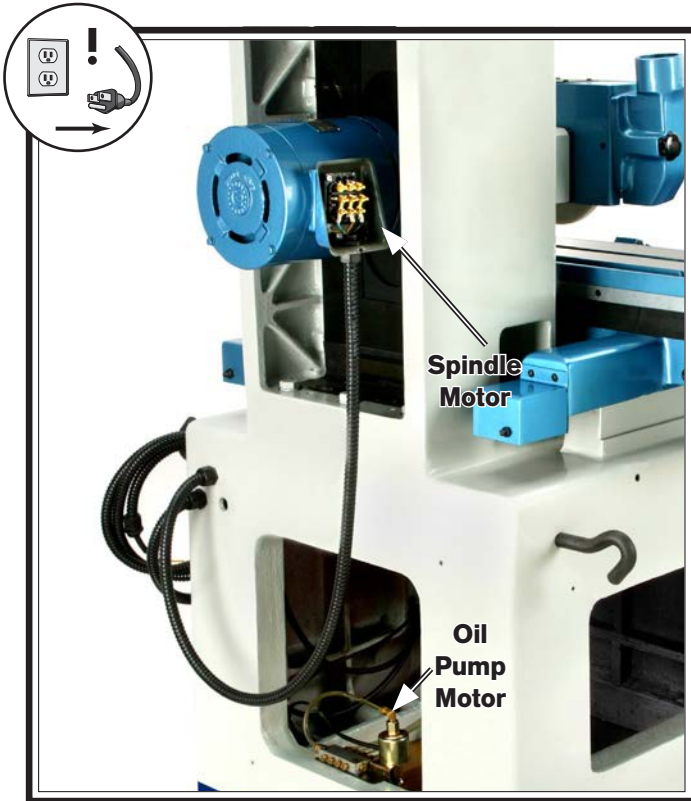

Figure 57. Spindle motor & pump motor locations.

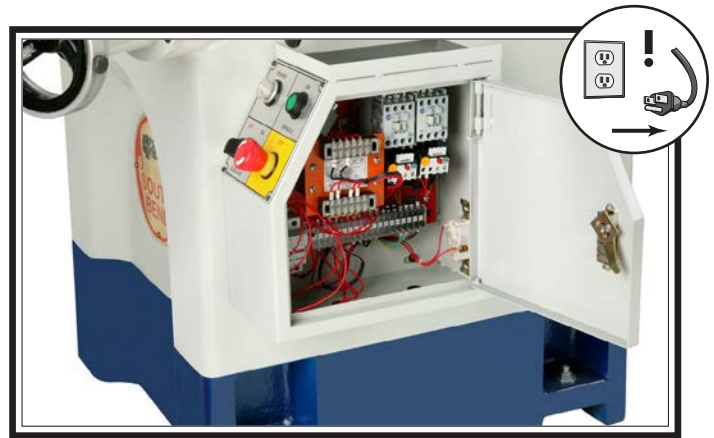
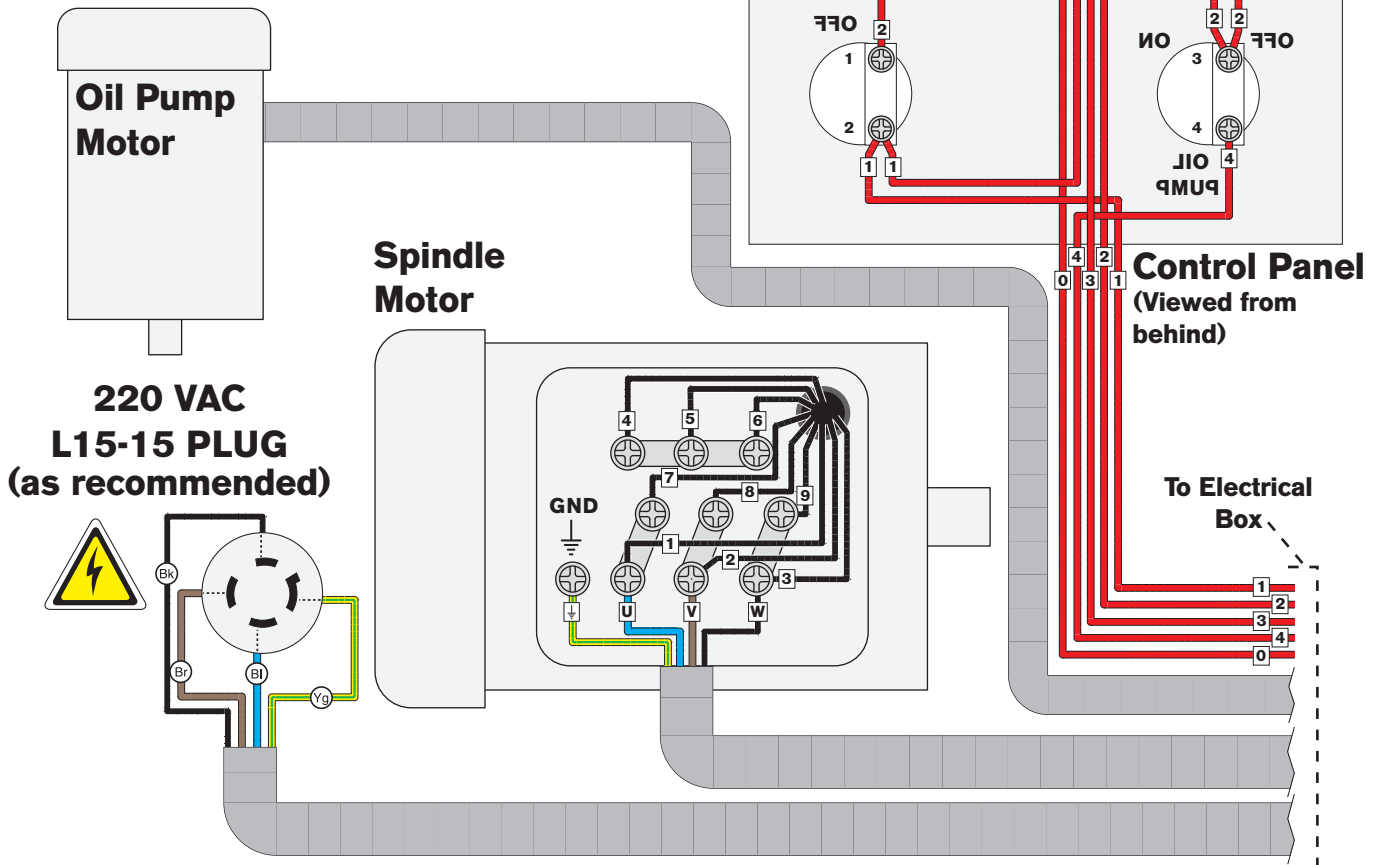
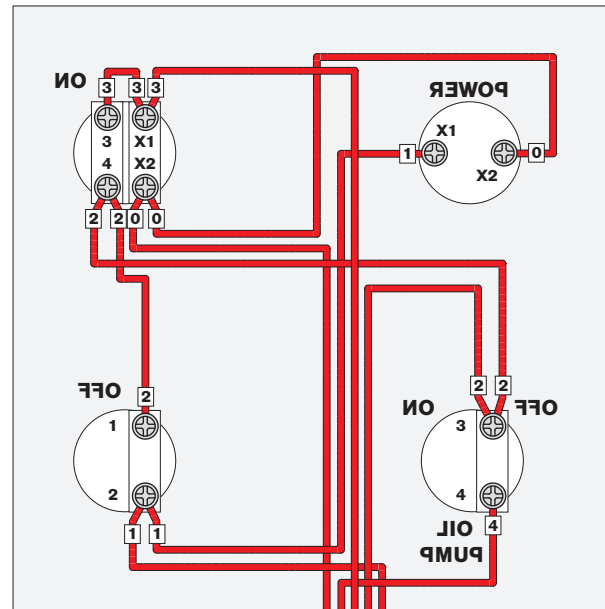
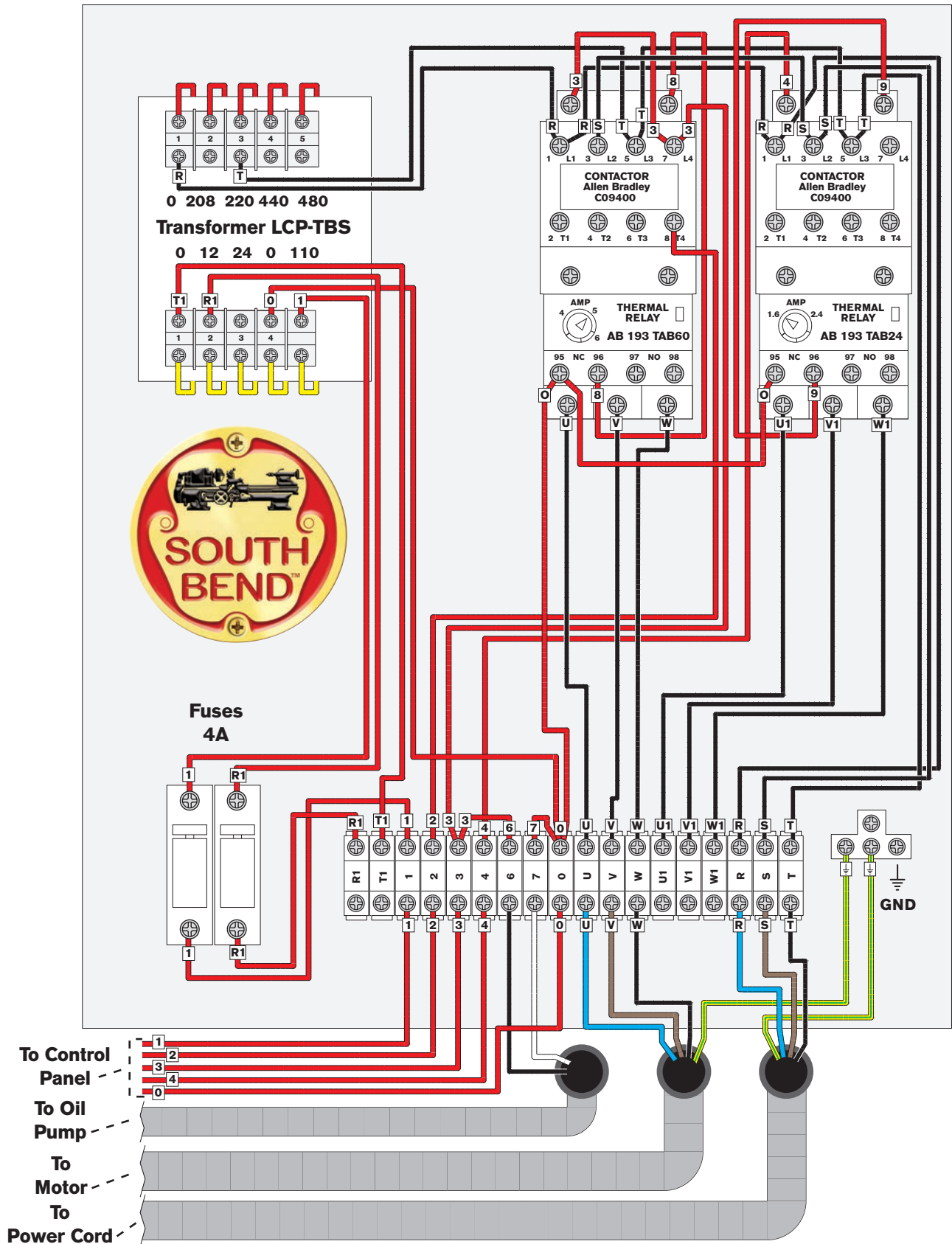

Fig. 58. Electrical box & control panel location.



220V Electrical Box



READ ELECTRICAL SAFETY ON PAGE 39 FIRST!



440V Electrical Components

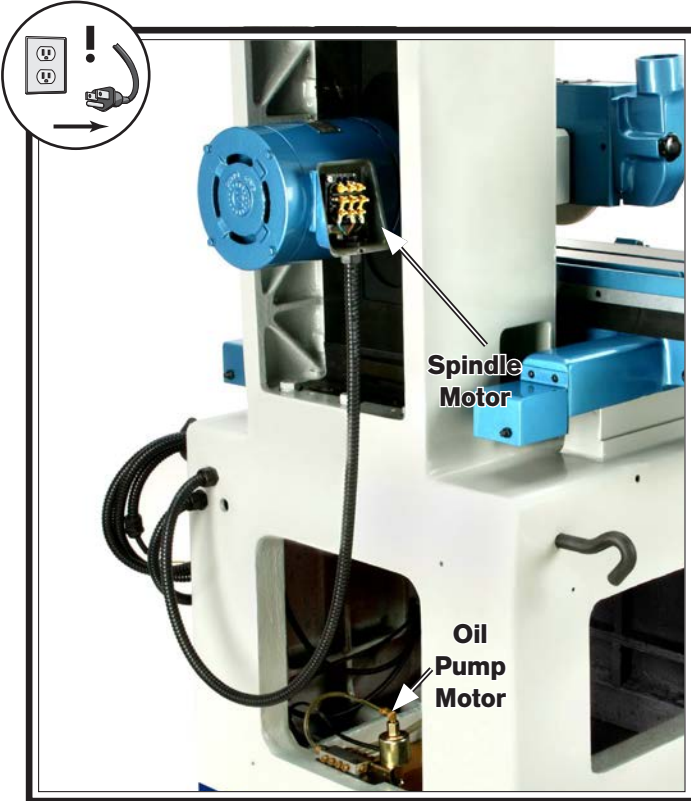

Figure 59. Spindle motor & pump motor locations.

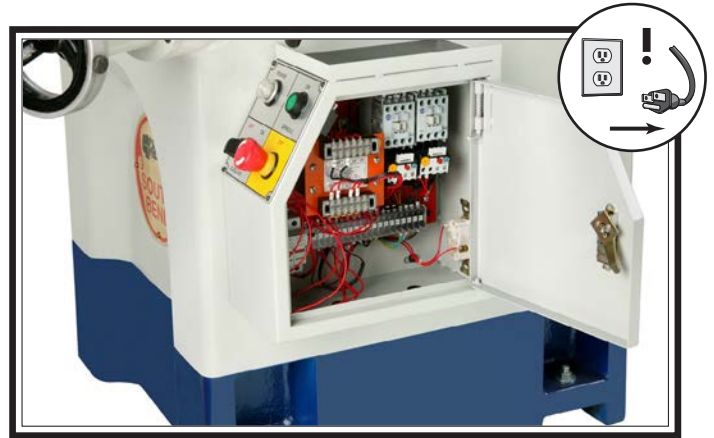
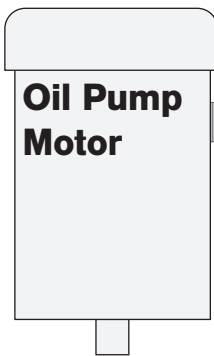
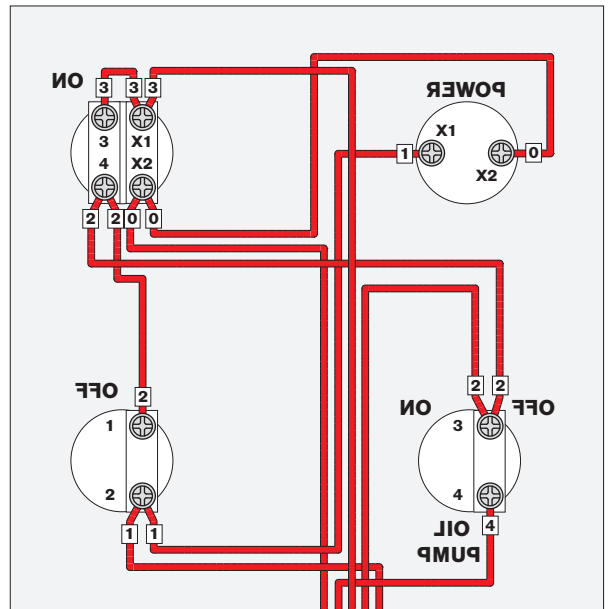
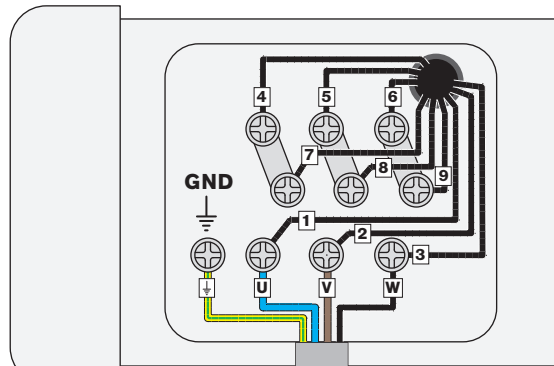

Figure 60. Electrical box & control panel location.



Spindle Motor



Control Panel (Viewed from behind)

To Electrical Box

For 440V: Disconnect Switch

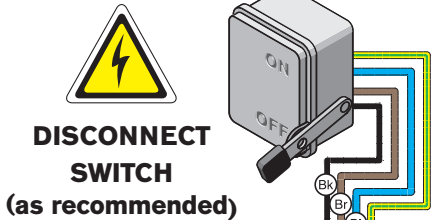

For 440V: Motor Rewired



Electrical Box

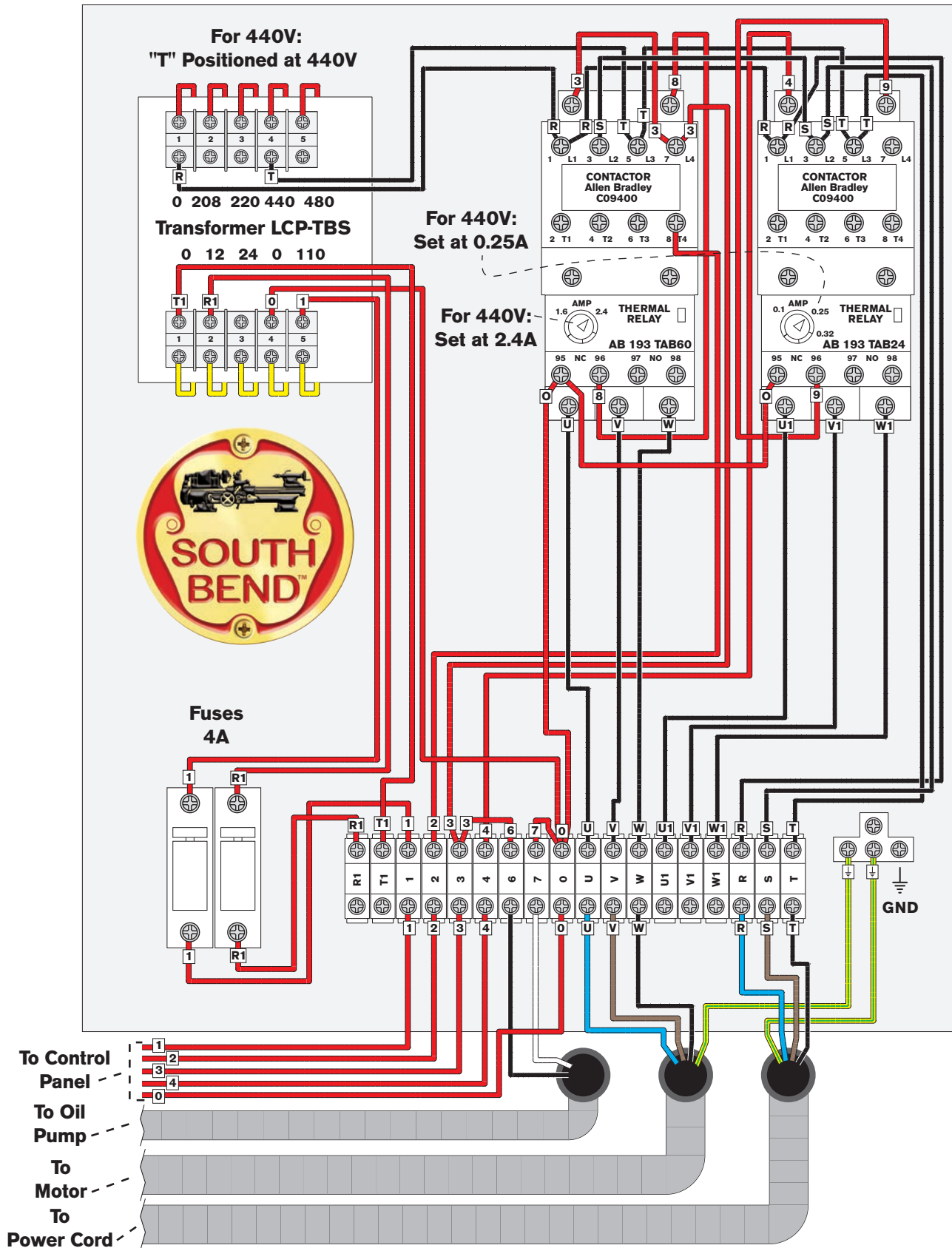

**READ ELECTRICAL SAFETY
ON PAGE 39 FIRST!**



Column

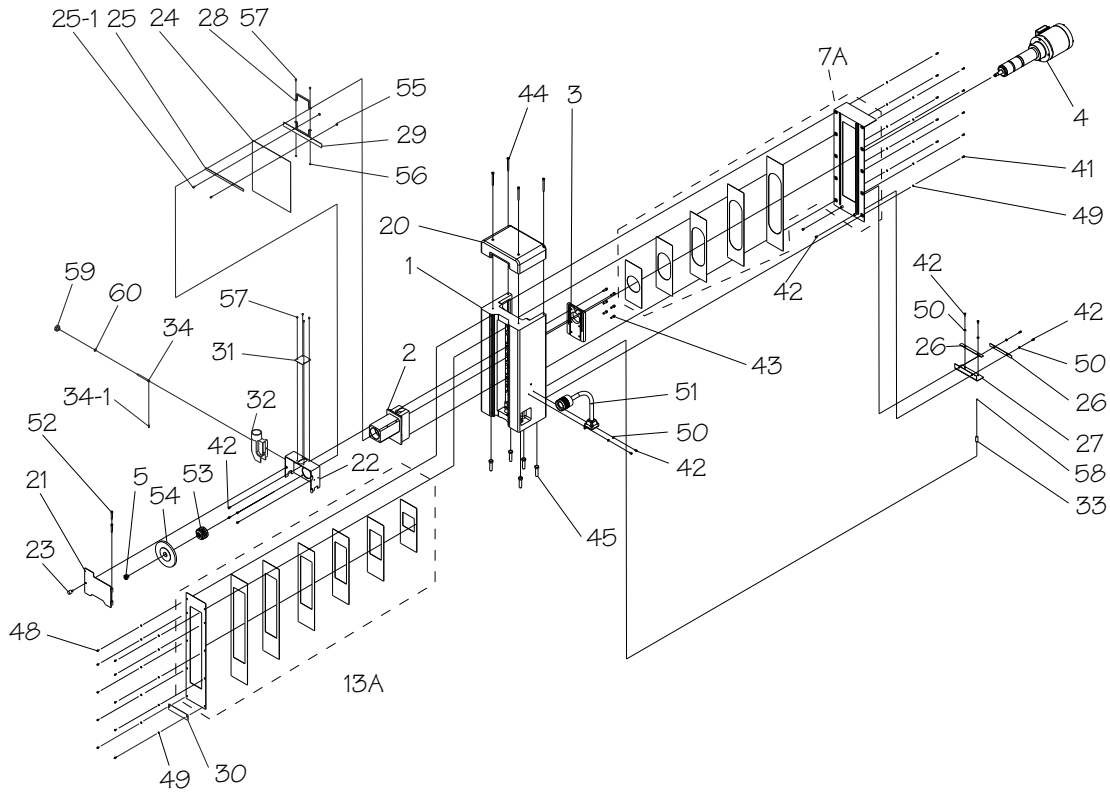

REF	PART #	DESCRIPTION
1	PSB1029001	COLUMN
2	PSB1029002	WHEEL HEAD
3	PSB1029003	REAR COVER
4	PSB1029004	SPINDLE
5	PSB1029005	WHEEL LOCK NUT
7A	PSB1029007A	REAR TELESCOPIC COVER ASSEMBLY
13A	PSB1029013A	FRONT TELESCOPIC COVER ASSEMBLY
20	PSB1029020	COLUMN COVER
21	PSB1029021	WHEEL ACCESS COVER
22	PSB1029022	WHEEL GUARD
23	PSB1029023	KNURLED STEEL KNOB M8-1.25 X 16
24	PSB1029024	DUST COVER
25	PSB1029025	DUST COVER CLAMP
25-1	PSB1029025-1	BUTTON HD CAP SCR M6-1 X 12
26	PSB1029026	LOWER DUST COVER CLAMP
27	PSB1029027	LOWER DUST COVER
28	PSB1029028	DUST COVER BRACKET
29	PSB1029029	DUST BRACKET CLAMP
30	PSB1029030	TELESCOPIC COVER BRACKET
31	PSB1029031	CHIP GUARD PLATE
32	PSB1029032	CHIP CHUTE

REF	PART #	DESCRIPTION
33	PSB1029033	DRAIN LINE
34	PSB1029034	DRILLED HD BOLT M8-1.23 X 100
34-1	PSB1029034-1	ROLL PIN 3 X 20
41	PSB1029041	CAP SCREW M5-.8 X 12
42	PSB1029042	CAP SCREW M6-1 X 12
43	PSB1029043	CAP SCREW M8-1.25 X 25
44	PSB1029044	CAP SCREW M8-1.25 X 90
45	PSB1029045	HEX BOLT M16-2 X 65
48	PSB1029048	BUTTON HD CAP SCR M5-.8 X 12
49	PSB1029049	FLAT WASHER 5MM
50	PSB1029050	FLAT WASHER 6MM
51	PSB1029051	WORK LAMP
52	PSB1029052	ROLL PIN 8 X 55
53	PSB1029053	WHEEL FLANGE ASSEMBLY
54	PSB1029054	GRINDING WHEEL 7.5D X .5W X 1.25B
55	PSB1029055	HEX NUT M6-1
56	PSB1029056	HEX NUT M5-.8
57	PSB1029057	BUTTON HD CAP SCR M6-1 X 10
58	PSB1029058	STEEL FLUTED RIVET 2 X 6MM
59	PSB1029059	KNOB M8-1.25
60	PSB1029060	FLAT WASHER 8MM

Elevation Control

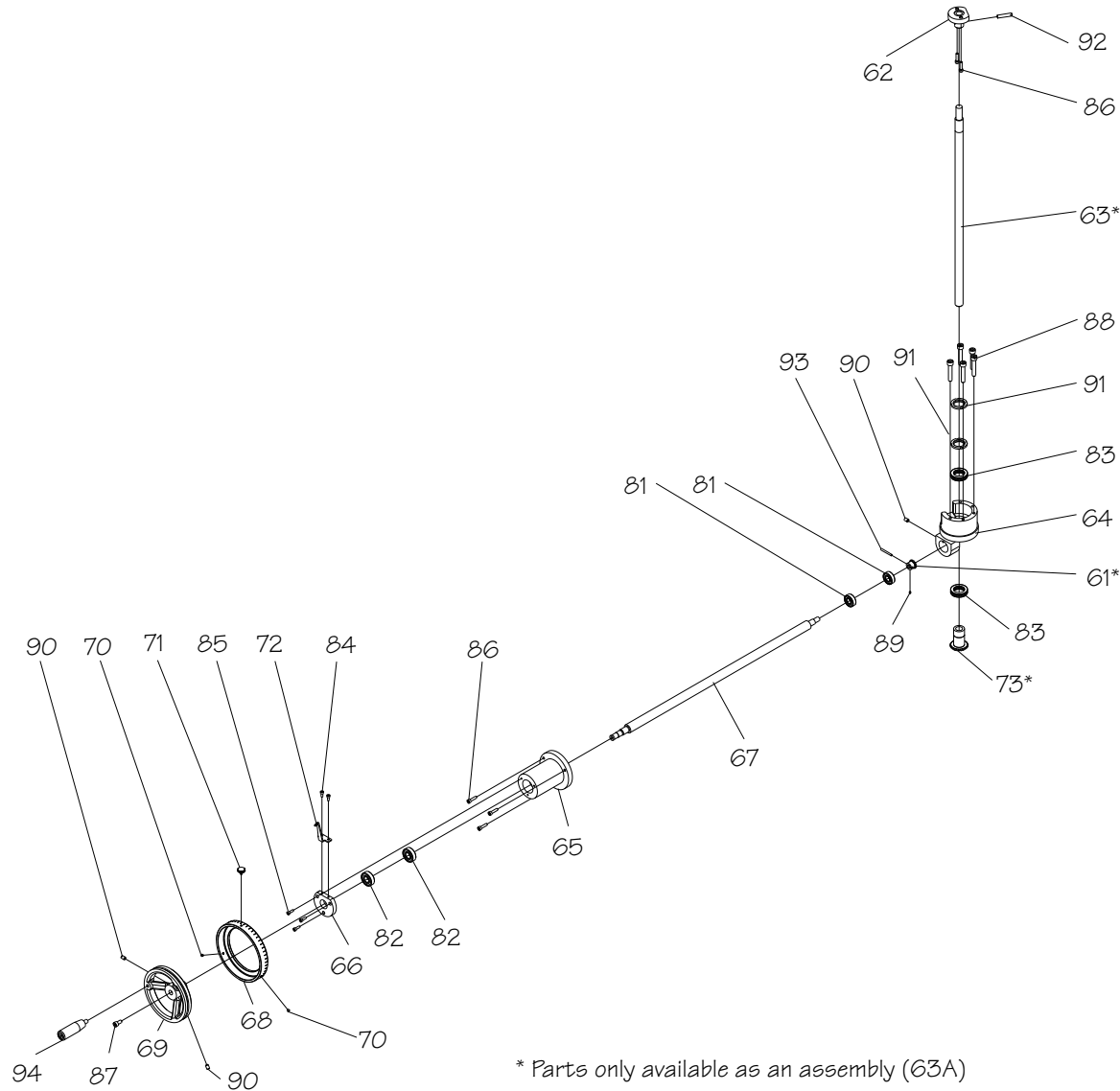

* Parts only available as an assembly (63A)

REF	PART #	DESCRIPTION
61	PSB1029061	SMALL LEVEL GEAR
62	PSB1029062	CONNECTOR
63	PSB1029063	VERTICAL LEADSCREW
63A	PSB1029063A	VERTICAL LEADSCREW W/ BEVEL GEARS
64	PSB1029064	BEVEL GEAR BRACKET
65	PSB1029065	SHAFT HOUSING
66	PSB1029066	BEARING COVER
67	PSB1029067	SHAFT
68	PSB1029068	GRADUATED DIAL
69	PSB1029069	VERTICAL HANDWHEEL
70	PSB1029070	SET SCREW M6-1 X 8
71	PSB1029071	KNURLED SCREW M6-1 X 12
72	PSB1029072	INDICATOR
73	PSB1029073	BEVEL GEAR

REF	PART #	DESCRIPTION
81	PSB1029081	BALL BEARING 6202ZZ
82	PSB1029082	BALL BEARING 6203ZZ
83	PSB1029083	THRUST BEARING TB51106
84	PSB1029084	CAP SCREW M5-.8 X 12
85	PSB1029085	CAP SCREW M5-.8 X 16
86	PSB1029086	CAP SCREW M6-1 X 25
87	PSB1029087	CAP SCREW M8-1.25 X 16
88	PSB1029088	CAP SCREW M10-1.5 X 55
89	PSB1029089	SET SCREW M4-.7 X 5
90	PSB1029090	SET SCREW M8-1.25 X 12
91	PSB1029091	LEADSCREW SPANNER NUT
92	PSB1029092	TAPER PIN M8 X 40
93	PSB1029093	TAPER PIN M4 X 40
94	PSB1029094	VERTICAL HANDWHEEL HANDLE

Table

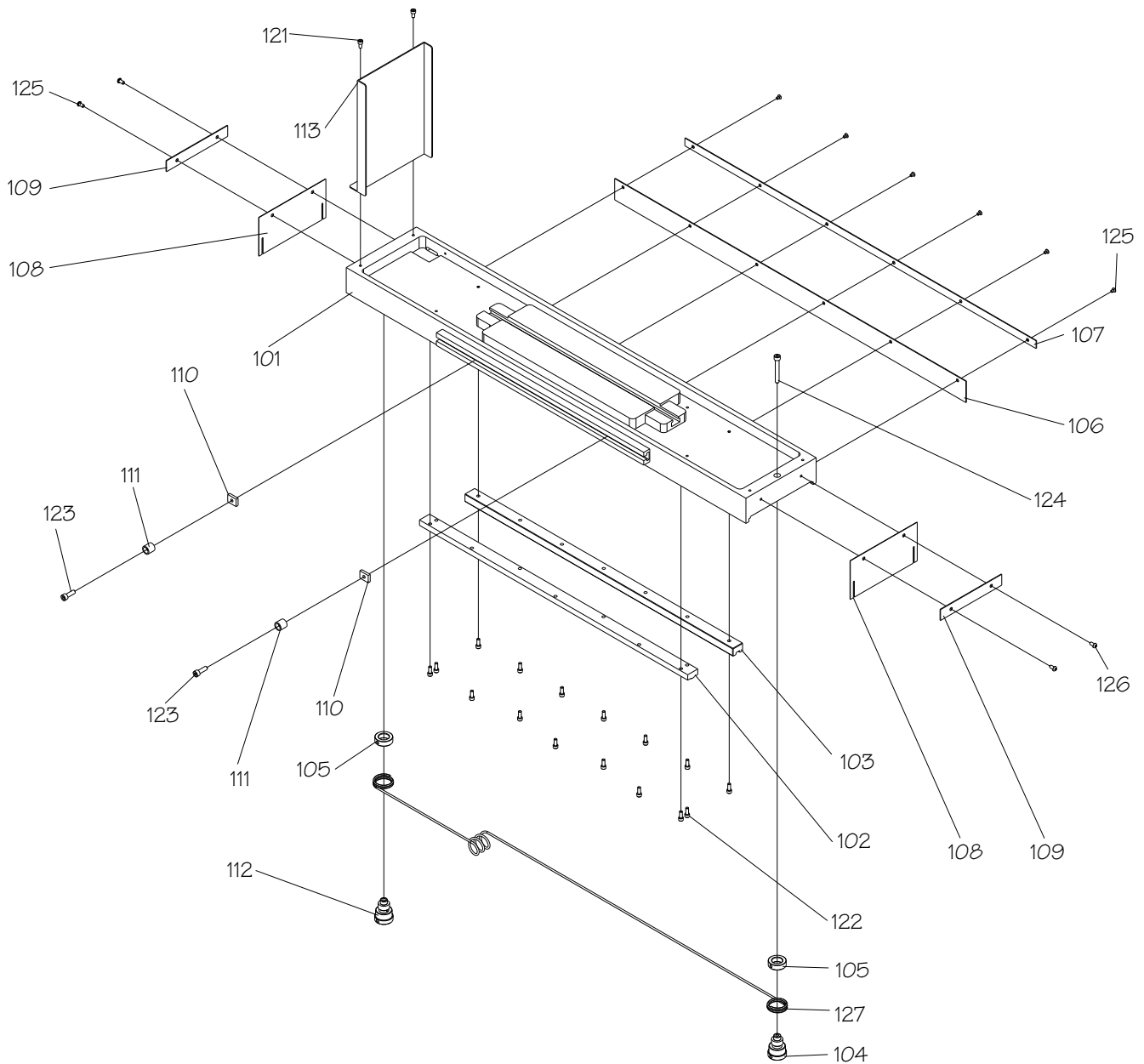

REF	PART #	DESCRIPTION
101	PSB1029101	TABLE
102	PSB1029102	FRONT RAIL
103	PSB1029103	REAR RAIL
104	PSB1029104	LEFT CABLE SPOOL
105	PSB1029105	CABLE PULLEY COLLAR
106	PSB1029106	WIPER
107	PSB1029107	FIXED PLATE
108	PSB1029108	RUBBER PLATE
109	PSB1029109	FIXED PLATE
110	PSB1029110	SQUARE NUT M8-1.25

REF	PART #	DESCRIPTION
111	PSB1029111	STOP PIN
112	PSB1029112	RIGHT CABLE SPOOL
113	PSB1029113	DUST GUARD
121	PSB1029121	CAP SCREW M6-1 X 12
122	PSB1029122	CAP SCREW M6-1 X 16
123	PSB1029123	CAP SCREW M8-1.25 X 25
124	PSB1029124	CAP SCREW M8-1.25 X 60
125	PSB1029125	FLAT HD SCR M5-.8 X 8
126	PSB1029126	BUTTON HD CAP SCR M6-1 X 12
127	PSB1029127	CABLE

Base

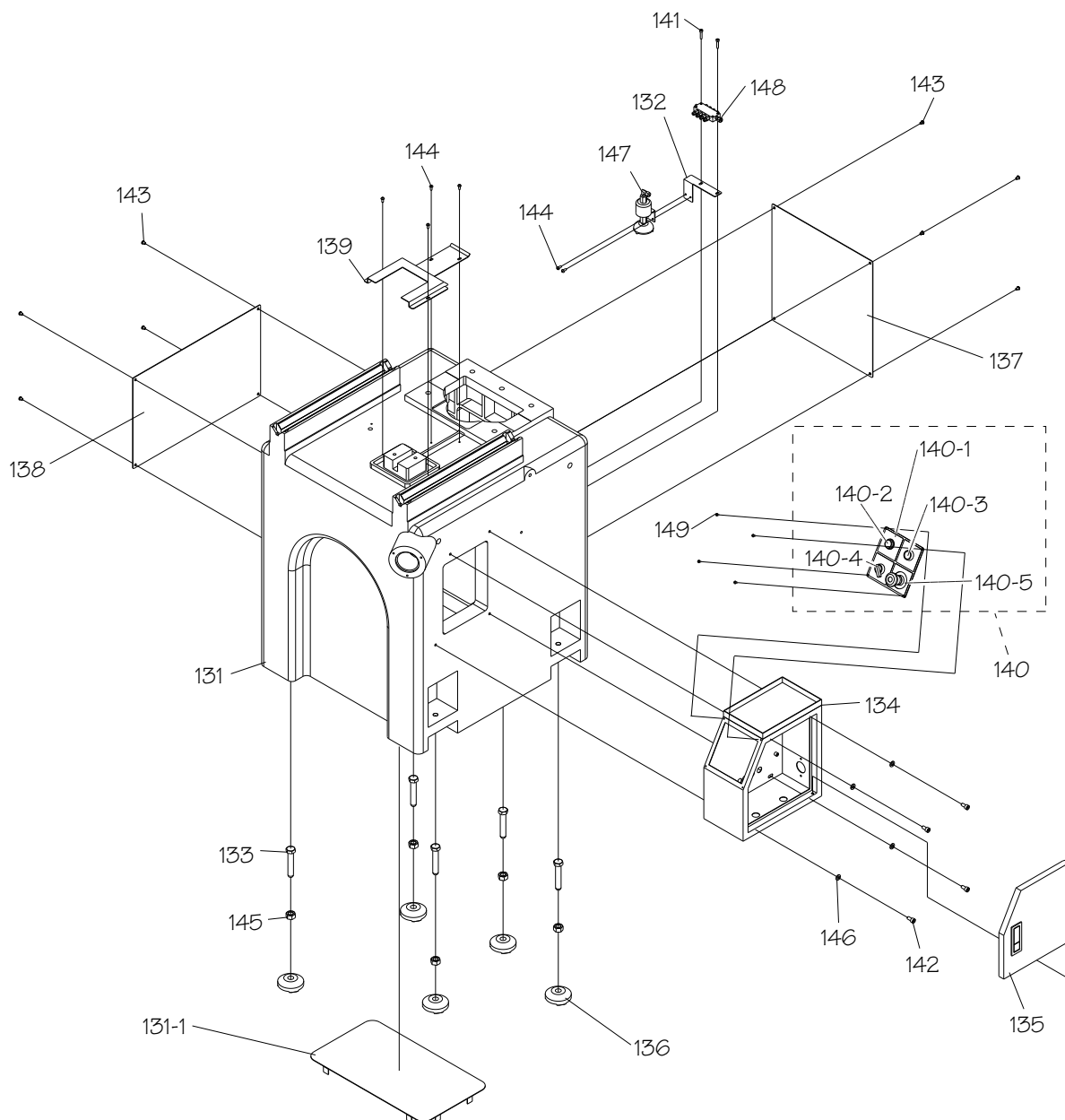

REF	PART #	DESCRIPTION
131	PSB1029131	BASE
131-1	PSB1029131-1	BOTTOM COVER
132	PSB1029132	PUMP SEAT
133	PSB1029133	FOOT BOLT M16-2 X 88
134	PSB1029134	CONTROL BOX
135	PSB1029135	BOX COVER
136	PSB1029136	FOOT
137	PSB1029137	BACK COVER
138	PSB1029138	LEFT SIDE COVER
139	PSB1029139	TOP COVER
140	PSB1029140	CONTROL PANEL ASSEMBLY
140-1	PSB1029140-1	CONTROL PANEL COVER
140-2	PSB1029140-2	INDICATOR LAMP

REF	PART #	DESCRIPTION
140-3	PSB1029140-3	POWER BUTTON
140-4	PSB1029140-4	PUMP SWITCH
140-5	PSB1029140-5	EMERGENCY STOP BUTTON
141	PSB1029141	CAP SCREW M5-.8 X 25
142	PSB1029142	CAP SCREW M8-1.25 X 16
143	PSB1029143	BUTTON HD CAP SCR M6-1 X 8
144	PSB1029144	BUTTON HD CAP SCR M5-.8 X 12
145	PSB1029145	HEX NUT M16-2
146	PSB1029146	FLAT WASHER 8MM
147	PSB1029147	PUMP
148	PSB1029148	OIL ADJUST VALVE
149	PSB1029149	BUTTON HD CAP SCR M4-.7 X 8

Saddle

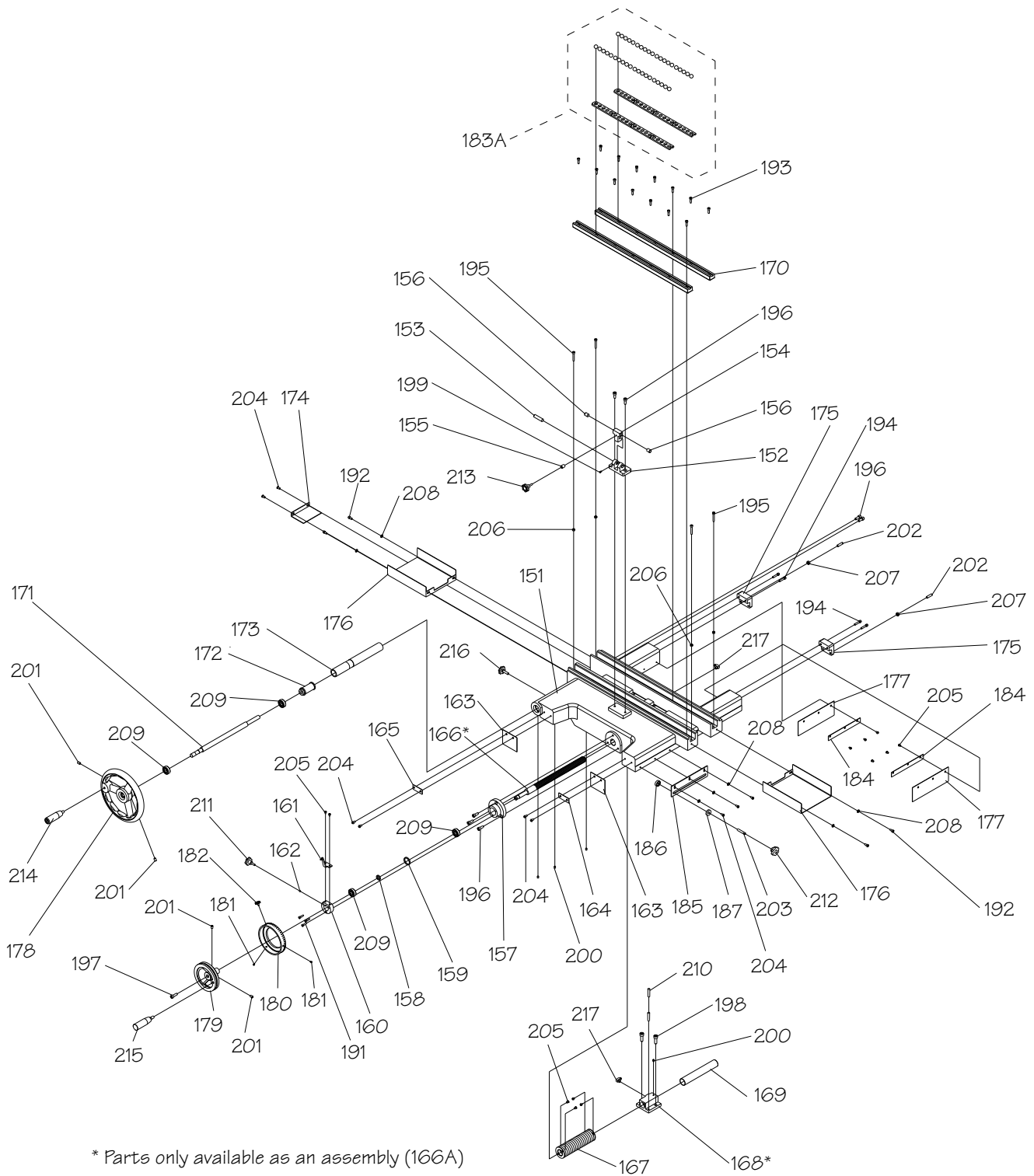

* Parts only available as an assembly (166A)

Main Assembly List

REF	PART #	DESCRIPTION	REF	PART #	DESCRIPTION
151	PSB1029151	SADDLE	183A	PSB1029183A	TABLE BEARING ASSEMBLY
152	PSB1029152	STOPPER BRACKET	184	PSB1029184	FIXED PLATE
153	PSB1029153	STOP BLOCK HINGE PIN	185	PSB1029185	LIMIT PLATE
154	PSB1029154	STOPPER	186	PSB1029186	COLLAR NUT M8-1.25
155	PSB1029155	RING	187	PSB1029187	SPACER 8MM
156	PSB1029156	STOP PIN	191	PSB1029191	CAP SCREW M5-.8 X 20
157	PSB1029157	HANDWHEEL BRACKET	192	PSB1029192	CAP SCREW M6-1 X 12
158	PSB1029158	INNER SPACER	193	PSB1029193	CAP SCREW M6-1 X 20
159	PSB1029159	OUTER SPACER	194	PSB1029194	CAP SCREW M6-1 X 30
160	PSB1029160	INDICATOR SEAT	195	PSB1029195	CAP SCREW M6-1 X 40
161	PSB1029161	INDICATOR	196	PSB1029196	CAP SCREW M8-1.25 X 20
162	PSB1029162	FLAT WASHER 6MM	197	PSB1029197	CAP SCREW M8-1.25 X 25
163	PSB1029163	RUBBER CHIP GUARD	198	PSB1029198	CAP SCREW M10-1.5 X 30
164	PSB1029164	CHIP GUARD PLATE	199	PSB1029199	SET SCREW M5-.8 X 4
165	PSB1029165	CHIP GUARD PLATE	200	PSB1029200	SET SCREW M6-1 X 8
166	PSB1029166	CROSS FEED LEADSCREW	201	PSB1029201	SET SCREW M8-1.25 X 12
166A	PSB1029166A	CROSS LEADSCREW ASSEMBLY	202	PSB1029202	SET SCREW M8-1.25 X 30
167	PSB1029167	LEAD SCREW COVER	203	PSB1029203	SET SCREW M8-1.25 X 45
168	PSB1029168	LEADSCREW NUT	204	PSB1029204	SET SCREW M6-1 X 12
169	PSB1029166A	REAR DUST COVER	205	PSB1029205	SET SCREW M5-.8 X 8
170	PSB1029170	RAIL	206	PSB1029206	HEX NUT M6-1
171	PSB1029171	TRANSMISSION SHAFT	207	PSB1029207	HEX NUT M8-1.25
172	PSB1029172	CABLE DRUM	208	PSB1029208	FLAT WASHER 6MM
173	PSB1029173	SHAFT SLEEVE	209	PSB1029209	BALL BEARING 6202ZZ
174	PSB1029174	COVER	210	PSB1029210	TAPER PIN M8 X 40
175	PSB1029175	STOPPER	211	PSB1029211	KNOB BOLT M6-1 X 21
176	PSB1029176	PLATE	212	PSB1029212	KNOB M8-1.25
177	PSB1029177	RUBBER PLATE	213	PSB1029213	KNOB BOLT M6-1 X 21
178	PSB1029178	LONGITUDINAL HANDWHEEL	214	PSB1029214	LONGITUDINAL HANDWHEEL HANDLE
179	PSB1029179	CROSS HANDWHEEL	215	PSB1029215	CROSS HANDWHEEL HANDLE
180	PSB1029180	GRADUATED DIAL	216	PSB1029216	KNOB BOLT M8-1.25 X 30
181	PSB1029181	CHECK NUT	217	PSB1029217	90 DEGREE OIL FITTING
182	PSB1029182	RATCHET NUT	218	PSB1029218	HARDENED STEEL BALL 5/8"
183	PSB1029183	STEEL BALL RETAINER			

Tools

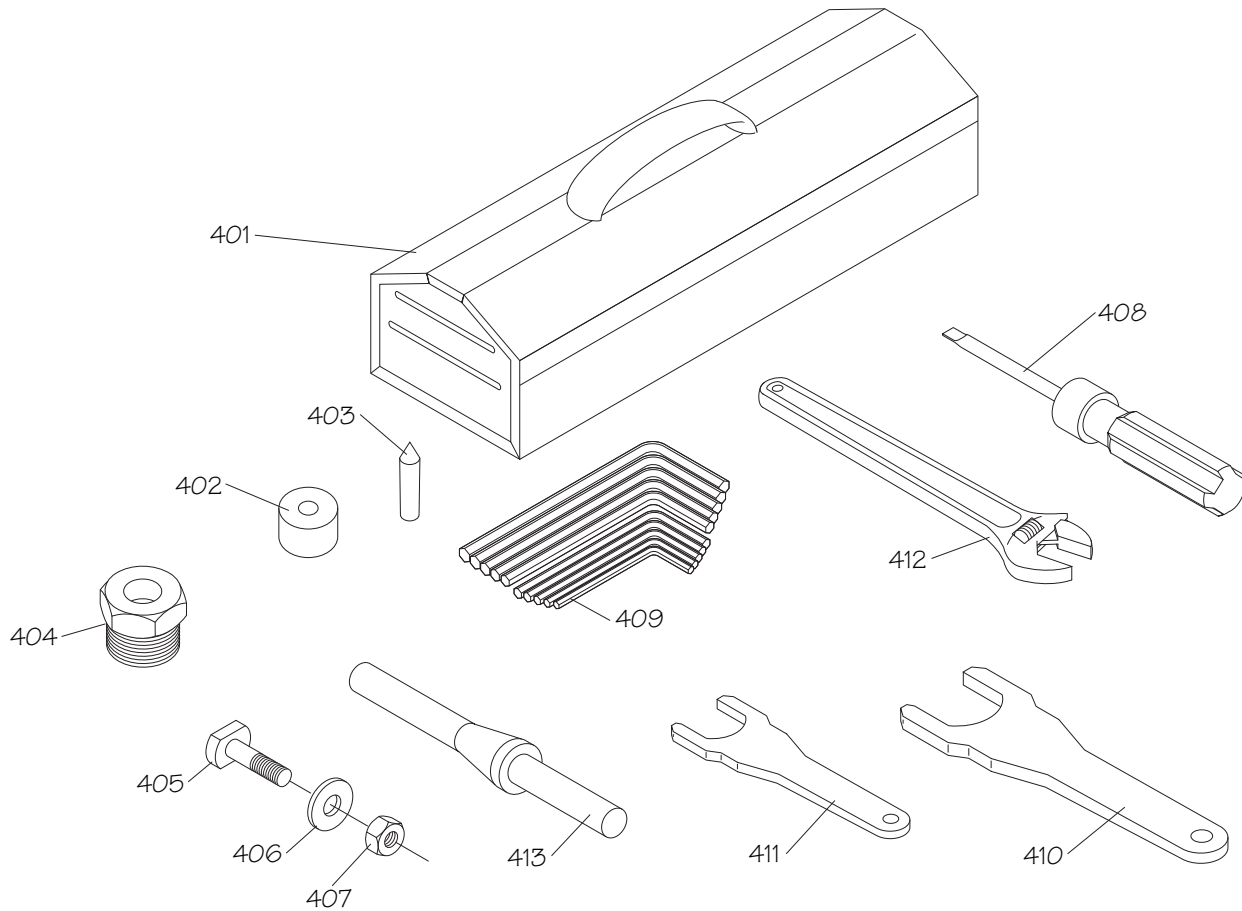

REF	PART #	DESCRIPTION
401	P5B1029401	TOOL BOX
402	P5B1029402	DRESSING TOOL BASE
403	P5B1029403	DIAMOND-TIP DRESSER
404	P5B1029404	HUB PULLER
405	P5B1029405	T-BOLT 1/2-12 x 2
406	P5B1029406	FLAT WASHER 1/2
407	P5B1029407	HEX NUT 1/2-12

REF	PART #	DESCRIPTION
408	P5B1029408	SCREWDRIVER FLAT #2
409	P5B1029409	HEX WRENCH SET 10PC 1.5-10 MM
410	P5B1029410	SPINDLE WRENCH 47MM
411	P5B1029411	SPINDLE WRENCH 27MM
412	P5B1029412	ADJUSTABLE WRENCH 8"
413	P5B1029413	BALANCING SPINDLE

Electrical

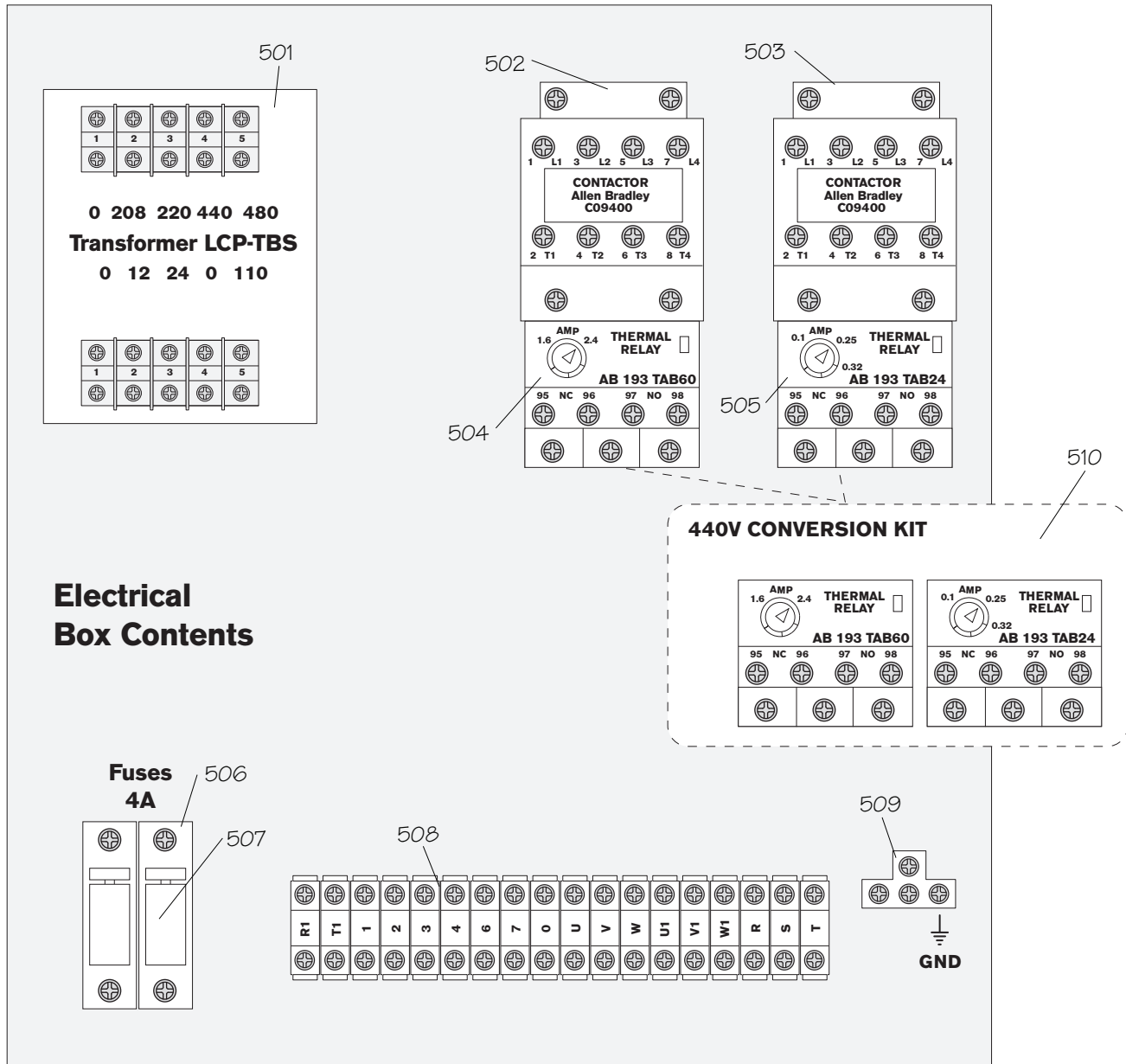

REF	PART #	DESCRIPTION
501	PSB1029501	TRANSFORMER LCP-TBS 0-480V
502	PSB1029502	CONTACTOR AB C09400 24V
503	PSB1029503	CONTACTOR AB C09400 24V
504	PSB1029504	RELAY 1.6-2.4A 193-TAB 60 (220/440V CONV.)
505	PSB1029505	RELAY 0.1-0.32A 193-TAB 24 (220V ONLY)

REF	PART #	DESCRIPTION
506	PSB1029506	FUSE HOLDER
507	PSB1029507	FUSE 4A
508	PSB1029508	TERMINAL BLOCK 18P
509	PSB1029509	GROUNDING BLOCK
510	PSB1029510	RELAY 0.1-0.32A 193-TAB 24 (440V CONV.)

Machine Labels

301 MODEL SB1029 6" x 18" SURFACE GRINDER

WARNING!
TO REDUCE THE RISK OF SERIOUS PERSONAL INJURY WHILE USING THIS MACHINE:

1. Read and understand manual before starting.
2. Always wear eye protection and respirator.
3. Always lockout and down wheel before use.
4. Never place hands near rotating machine parts or workpiece.
5. Never use hand to hold workpiece while grinding.
6. Inspect wheel before each use. Never use grinding wheel that has been chipped or has chips or cracks. Inspect wheel before each use.
7. Do not wear loose fitting gloves or jewelry. Secure long hair and button up long sleeve shirts.
8. Disconnect power before servicing, setting up or adjusting.
9. Do not use grinding wheels rated lower than 3450 RPM.
10. Do not operate under the influence of drugs or alcohol.
11. Make sure machine is properly adjusted, set up, and workpiece is clamped before starting work.
12. Keep floor area around the grinder clean and dry.
13. Never leave the machine running unattended.

302 NOTICE

TIPS FOR BEST GRINDING RESULTS:

- Make sure the grinding wheel is balanced before use.
- Select an appropriate grinding wheel according to the workpiece material.
- Keep a thin coat of oil on the spindle nose and wheel flange to prevent rust.
- Never use compressed air to clean the machine. Doing so will force metal chips into the table ways.
- Keep longitudinal handwheel drive cable properly adjusted.
- Empty, clean, and refill oil reservoir every 3-6 months.
- Adjust oil flow as necessary to maintain smooth operation of all moving parts.
- Clean dust collection at least weekly, or any time you notice a drop in suction.

303 WARNING! TIPPING HAZARD DO NOT place a heavy object on one end of the table. Doing so may cause the table to tip, resulting in personal injury or damage to machine.

304 WARNING! High Voltage

305 NOTICE

Before using machine, remove this cover and make sure the lubrication tank is filled with Mobil Vaseline 100 or equivalent oil (ISO 32 Way Oil) to provide lubrication to the ways.

306

1. Vertical Leadcrew
2. Cross Leadcrew
3. Longitudinal & Cross Slideways
4. Pressure Discharge

- Turning valve counterclockwise reduces oil flow.
- Turning valve clockwise increases oil flow.
- To restore factory settings: Valve 1: Turn fully counterclockwise (full flow). Valve 2 & 3: Turn clockwise until stop, then back 1 turn. Valve 4: Turn clockwise until stop, then loosen until steady drip is observed (about 3 drops per second).

307 WARNING! POISON BIOHAZARD Refer to the cutting fluid manufacturer's Material Safety Data Sheet (MSDS) for safety information.

308 220V 3-Ph

309 INJURY CHECK HAZARD To avoid shock or accidental starting, disconnect power before repairing or servicing machine.

310 NOTICE

If excessive play develops in the longitudinal handwheel, the cable drive can be tightened. See your Owner's Manual for details.

311 INJURY HAZARD Do not use machine if you have not read the manual. Visit www.southbend.com or call 300-726-1540 to get a manual.

312 INJURY HAZARD Do not use machine if you have not read the manual. Visit www.southbend.com or call 300-726-1540 to get a manual.

313 WARNING! High Voltage

314 INJURY HAZARD Do not use machine if you have not read the manual. Visit www.southbend.com or call 300-726-1540 to get a manual.

315 NOTICE

Only trained and properly supervised personnel are allowed to operate this machine. If safe operation procedures are not clearly understood, request additional training from a supervisor before beginning operation.

316 NOTICE

Before using the machine, tilt the table and remove the four plastic shipping support blocks from both ends. Save these blocks for future transport of the machine.

317 WARNING! EYE/FACE/LUNG INJURY HAZARD Always wear a face shield and respirator when using this equipment.

318 WARNING! EYE/FACE/LUNG INJURY HAZARD Always wear a face shield and respirator when using this equipment.

319 WARNING! EYE/FACE/LUNG INJURY HAZARD Always wear a face shield and respirator when using this equipment.

320 WARNING! EYE/FACE/LUNG INJURY HAZARD Always wear a face shield and respirator when using this equipment.

321 NOTICE

Before using the machine, tilt the table and remove the four plastic shipping support blocks from both ends. Save these blocks for future transport of the machine.

322 WARNING! EYE/FACE/LUNG INJURY HAZARD Always wear a face shield and respirator when using this equipment.

323 WARNING! EYE/FACE/LUNG INJURY HAZARD Always wear a face shield and respirator when using this equipment.

324 WARNING! EYE/FACE/LUNG INJURY HAZARD Always wear a face shield and respirator when using this equipment.

325 WARNING! EYE/FACE/LUNG INJURY HAZARD Always wear a face shield and respirator when using this equipment.

326 WARNING! EYE/FACE/LUNG INJURY HAZARD Always wear a face shield and respirator when using this equipment.

Machine Labels List

REF	PART #	DESCRIPTION	REF	PART #	DESCRIPTION
301	PSB1029301	MACHINE ID LABEL	316	PSB1029316	SOUTH BEND NAMEPLATE 5 203MM
302	PSB1029302	BEST GRINDING RESULTS LABEL	317	PSB1029317	SB DARK BLUE TOUCH-UP PAINT
303	PSB1029303	TABLE TIP WARNING LABEL	318	PSB1029318	SB GRAY TOUCH-UP PAINT
304	PSB1029304	ELECTRICITY LABEL 1.4	319	PSB1029319	MODEL NUMBER LABEL
305	PSB1029305	CHECK LUBRICANT LABEL	320	PSB1029320	EYE/FACE/LUNG LABEL 2 X 3.25
306	PSB1029306	MANIFOLD ADJUSTMENT LABEL	321	PSB1029321	REMOVE BLOCKS HANG TAG
307	PSB1029307	BIOHAZARD LABEL 3.25 X 2	322	PSB1029322	SB LIGHT BLUE TOUCH-UP PAINT
310	PSB1029310	CABLE DRIVE ADJUSTMENT LABEL	323	PSB1029323	ROTATION LABEL
311	PSB1029311	220V 3-PH LABEL	324	PSB1029324	TRAINED PERSON ONLY LABEL
312	PSB1029312	DISC POWER LABEL 2 X 3.25	325	PSB1029325	SOUTH BEND NAMEPLATE 3 90MM
313	PSB1029313	ELECTRICITY LABEL 1.4	326	PSB1029326	SOUTH BEND LOGO RECT
314	PSB1029314	READ MANUAL LABEL 2 X 3.25			

WARNING

The safety labels provided with your machine are used to make the operator aware of the machine hazards and ways to prevent injury. The owner of this machine **MUST** maintain the original location and readability of these safety labels. If any label is removed or becomes unreadable, **REPLACE** that label before using the machine again. Contact South Bend Lathe Co. at (360) 734-1540 or www.southbendlathe.com to order new labels.

This quality product is warranted by South Bend Lathe Company to the original buyer for one year from the date of purchase. This warranty does not apply to consumable parts, or defects due to any kind of misuse, abuse, negligence, accidents, repairs, alterations or lack of maintenance. We do not reimburse for third party repairs. In no event shall we be liable for death, injuries to persons or property, or for incidental, contingent, special or consequential damages arising from the use of our products.

We do not warrant or represent that this machine complies with the provisions of any law, act, code, regulation, or standard of any domestic or foreign government, industry, or authority. In no event shall South Bend's liability under this warranty exceed the original purchase price paid for this machine. Any legal actions brought against South Bend Lathe Company shall be tried in the State of Washington, County of Whatcom.

This is the sole written warranty for this machine. Any and all warranties that may be implied by law, including any merchantability or fitness, for any purpose, are hereby limited to the duration of this warranty. To take advantage of this warranty, contact us by mail or phone to give us the details of the problem you are having.

Thank you for your business and continued support.



southbendlathe.com



Printed In Taiwan

#CRJB12798